



**BROBO GROUP** ©

A.C.N. 098 264 316  
A.B.N. 42 098 264 316

**BROBO GROUP (AUST) PTY. LTD.**

8 Fowler Rd, Dandenong South  
Victoria 3175, AUSTRALIA.

+ 61 3 9794 8751

+ 61 3 9794 8792

[info@brobo.com.au](mailto:info@brobo.com.au)

[www.brobo.com.au](http://www.brobo.com.au)



## **PRODUCT AND MAINTENANCE MANUAL** **3M PRECISION DRILLING MACHINE**



**YOUR BROBO DISTRIBUTOR IS:**

- 
- Precision Drilling Machines • Tapping Machines • Multi-Head Drills • Tool Grinders •
  - Tool Post Grinders • Machine Vices • Special Production Equipment •
  - Accessories • Riveting Machines • Pedestal Grinders • Metal cutting Saws • Linishers •

# OPERATING MANUAL FOR **BROBO GROUP** 3M PRECISION DRILLING MACHINE

## TECHNICAL SPECIFICATION

### CHAPTER 1: Installation of the Machine

- 1.1 Unpacking & Handling the Machine
- 1.2 Parts Checklist
- 1.3 Minimum Requirements
- 1.4 Anchoring the drill
- 1.5 Connection to Power Source

### CHAPTER 2: Safety & Accident Prevention

- 2.1 Operation of the Machine
  - 2.1.1. Noise Level
  - 2.1.2. Power Supply
- 2.2 General Requirements
- 2.3 Advice for the Operator
- 2.4 Machine Safety Devices
  - 2.4.1. Reference Standards

### CHAPTER 3: Main Functions & Operation of the Machine

- 3.1.1. Drill Head
- 3.1.2. Safety Eye Shields
- 3.1.3. Depth Adjustment
- 3.1.4. Drill Racklift Table
- 3.1.5. Drill Column Support
- 3.2 Preparation for Operation
- 3.3 Operation Recommendations

### CHAPTER 4: Drawings, Layouts, Assembly & Spare Parts

- 4.1.1 Spare Parts
- 4.2.1 3M Drill Assembly
- 4.2.2 3M Drill Rack lift Table Assembly
- 4.2.3 3M Drill Head Assembly
- 4.2.4 3M Drill Head Assembly BOM
- 4.2.5 3M Drill Belt Guard Assembly (1031190)
- 4.2.6 3M Drill Toggle Assembly (2121180)
- 4.2.7 3M Drill Standard Switch Assembly (2131020)
- 4.2.8 3M Drill Chuck Guard Assembly (1301760)
- 4.2.9 3M Drill Column Support Assembly (Floor)
- 4.3.1 3M Drill Floor Mount
- 4.3.2 3M Drill Bench Mount

### CHAPTER 5: Maintenance & Selection of Consumables

- 5.1 Role of the Operator
- 5.2 Maintenance Requirements
- 5.3 General Maintenance of Functioning Components

### CHAPTER 6: Troubleshoot

- 6.1 General Troubleshooting

## APPENDIX

- i. Hazard/Risk Assessment
- ii. Brobo Group Warranty
- iii. Workplace Health & Safety Policy

# TECHNICAL SPECIFICATION

	3M SERIES (BENCH MOUNTED)	3M SERIES (FLOOR MOUNTED)
DRILLING CAPACITY	32mm	32mm
SIZE OF TABLE <ul style="list-style-type: none"> <li>• Standard Square</li> <li>• Optional Round</li> <li>• Optional T-Slots</li> </ul>	- - 305 × 305	- 350 305 × 305
SPINDLE TRAVEL	101	101
COLUMN DIAMETER	74.6	74.6
MAXIMUM DISTANCE SPINDLE TO TABLE	340	714
MAXIMUM DISTANCE SPINDLE TO BASE	530	1208
THROAT DEPTH	191	191
MOTOR KW	0.75	0.75
SPINDLE SPEEDS (NOMINAL) STRAIGHT DRIVE  INTERMEDIATE DRIVE	480, 850, 1450, 2500  150, 280, 320, 480, 570, 650, 1800, 2000, 3000	480, 850, 1450, 2500  150, 280, 320, 480, 570, 650, 1800, 2000, 3000
WEIGHT UNPACKED	130kg	145kg
WEIGHT PACKED	149kg	164kg
HEIGHT PACKED (mm)	985	1390
HEIGHT INSTALLED (mm)	985	1700
BASE AREA (mm)	368 × 600	368 × 600



# CHAPTER 1 - Installation of the Machine

---

## 1.1. Unpacking & Handling the Machine



### **WARNING – HEAD HEAVY MACHINES**

*The metal drilling machines are heaviest where the drill heads are fitted & as such, care must be taken while relocating or moving the machines.*

Upon receiving the **Robo Group 3M Drill**, the machine should be standing upright & positioned centrally on top of a wooden pallet. While the machine is situated on the pallet, position the forklift arms under the pallet between the runners, keeping in mind that the machine is **head heavy** & minimal force should be exerted on the electrical box located beneath the machine. Move the entire unit to an accessible area as close as possible to the final location.

Carefully remove the wooden frame surrounding the drill unit (*Figure 1*). Once completed, proceed by elevating the machine away from the pallet base using a sling harness wrapped around the entire unit ensuring that it is *equally supported*. Ensure that the floor is as level as possible before finally positioning the machine to the desired location.

Once in position, verify that the electrical supply is connected. Attached the 3MT arbour & chuck set (*not provided*) into the quill housing, while ensuring that the arbour steps correctly mates into the quill housing slot.

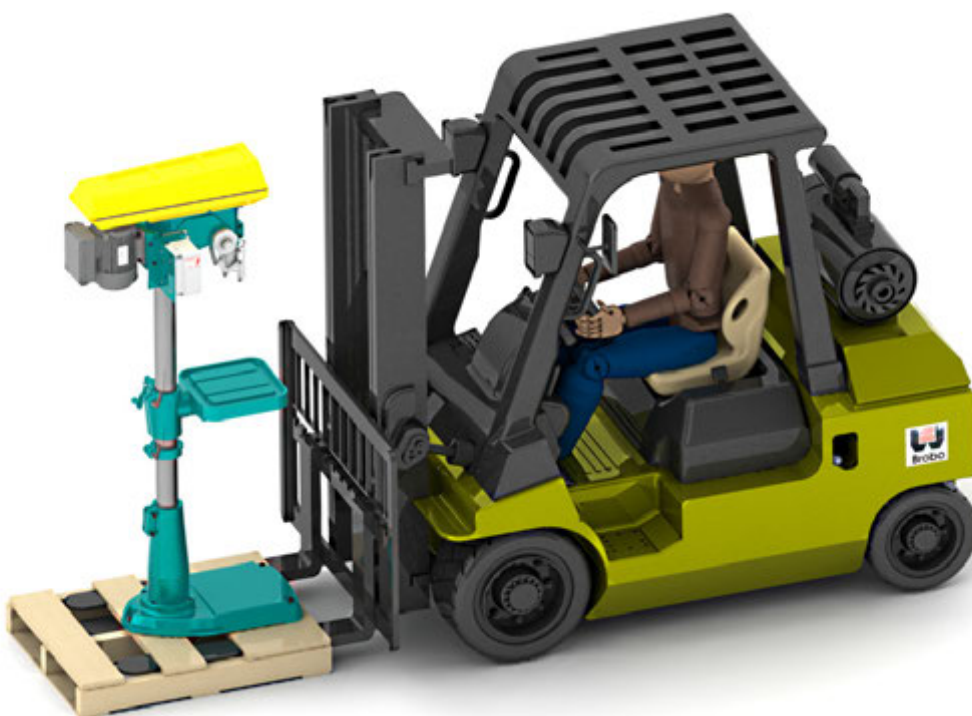

**Figure 1.** Handling of 3M Drill

**PLEASE OBSERVE & FOLLOW THE INSTALLATION INSTRUCTIONS ON PAGE 5**

## 1.2. Parts Checklist

Along with the drill unit, check that the following accessories, packed "loose", are included as follows:

### A. STANDARD ACCESSORIES

- 1) 1 × Operation Manual

## 1.3. Minimum Requirements

For the machine to function correctly, the room in which the drill unit is to be installed must be in the vicinity of, & satisfy the following conditions:

- 415/240V Power Supply
- Ambient Temperature - From -10 °C to +50 °C.
- Relative Humidity: Not more than 90%.
- Lighting: More than 500 LUX.



### **WARNING – OPERATING VOLTAGE VARIATION**

*Each drill model has an inbuilt safety system to protect it against voltage variations. However, for the machine to perform efficiently, ensure that the drill unit operates within  $\pm 10\%$  limits of the recommended voltage of the motor.*

## 1.4. Anchoring the Drill

Prior to anchoring the drill unit, take into considerations the requirements mentioned in *Section 1.3 & Section 2.2*, & other aspects regarding the usage of the machine such as accessibility to drilled parts & safe access for the operator.

The drill unit arrives fastened to the shipping pallet using 3 × M16 bolts provided. When positioning & fastening the drill, please refer to the hole locations shown in *Figure 2*.

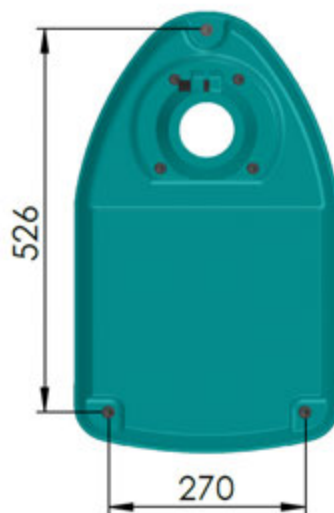

**Figure 2.** Anchoring Hole Locations



### **WARNING – EXCEEDING MAXIMUM HEIGHT**

*Do not extend the height of the machine past the maximum 'height installed' indicated. Exceeding past this limit will cause the column to extend out of the column support, which might subsequently cause damage to the machine, as well as causing injury to any person in the vicinity.*

## 1.5. Connection to Power Source

Before connecting the machine to the power supply, check that the socket is not connected in series with other machines. This condition is critical for the ideal operation of the drill unit.

### Single & Three Phase

- a) **Single phase machines** are provided with three pins, **15 amps** rated plugs & leads for connection to **240V**, **50Hz** power supply in **Australia**.

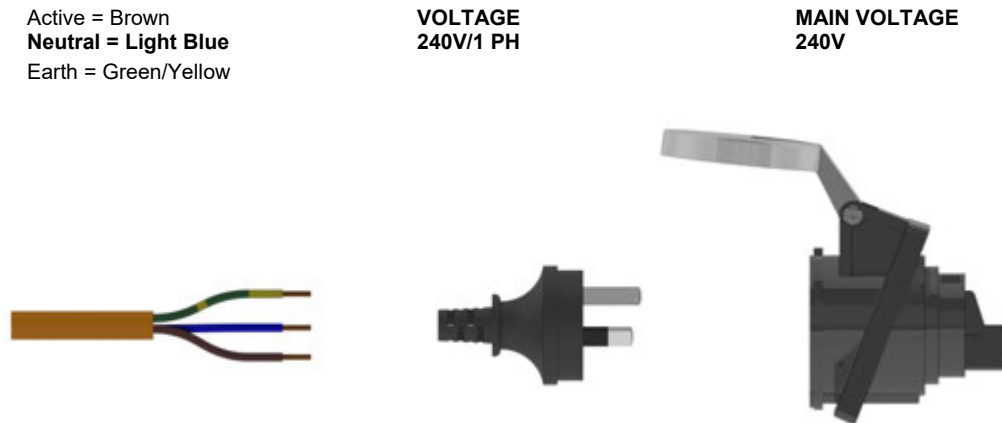

Figure 3.1 Connection 3 pins – 1 Phase

- b) **Three phase machines** should be fitted with a suitable, approved **four pin plugs** (i.e. three phase & earthing - **not provided**)



Figure 3.2 Connection for "4-CORE" Wire System with Neutral – 3 Phase

- c) Check the power supplied & motor specifications before plugging in the machine. Check the terminal connection on dual voltage motor terminal box & connect it accordingly to the corresponding voltage supply.

**To connect the machine to the power supply, proceed as follows:**

- 1) Ensure that all electrical leads & cables (including supply leads) are maintained in a good condition & away from sharp objects. All leads should be replaced if cut, sliced or damaged in any way.
- 2) Insert the power plug into the socket, while ensuring that the **mains voltage is compatible** for which the drill unit is operating at.
- 3) Inspect that the power switch on the main box is closed & set to **OFF** position
- 4) To prepare the machine for operation, release the **STOP/EMERGENCY STOP** button by twisting the red mushroom button. To activate the drill, engage the green **START** button.
- 5) Check that the spindle rotary direction & change the phasing if required; clockwise rotation observing top-down on top of the motor pulley
- 6) If all of the above procedures have been carried out correctly, the drill should now be operational

**Brobo Group 3M Drill** is now ready for use.

*Chapter 3 provides a detailed description of the various features of the drill & its operating cycles*



## CHAPTER 2 - Safety & Accident Prevention

---

The **Brobo Group 3M Drill** has been designed & manufactured in accordance with **Australian Standards**. It is **HIGHLY RECOMMENDED** that the instructions & warnings contained in this chapter be carefully followed for correct usage of the machine.

### 2.1. Operation of the Machine

The **Brobo Group 3M Drill** is specifically designed to drill through ferrous & metal cross sections with thin-walled or “plate” profiles. Other types of material & machining are not compatible for use with the specifications of the drill. ***This machine involves a high-speed revolution; therefore extreme caution is required when operating the device.***

The employer is responsible for instructing the personnel who, in turn, are obliged to inform the operator of any accident risks, safety devices, noise emission & accident prevention regulations provided for by national & international laws governing the use of the machine. ***The operator must be fully aware of the position & functions of all the machine’s controls.***

***All those concerned must strictly adhere to ALL instructions, warnings, & accident prevention standards in this manual.***

The following definitions are those provided for by the **EEC DIRECTIVE ON MACHINERY No. 98/37/CE**:

- **Danger Zone** - any zone in and/or around a machine in which the presence of a person constitutes a risk to the safety & health of that person.
- **Person Exposed** - any person finding him or herself, either completely or partly in a danger zone.
- **Operator** - the person or persons are given the responsibility of installing, operating, adjusting, maintaining, cleaning, repairing, & transporting the machine.



#### **WARNING – UNAUTHORISED MODIFICATIONS/REPLACEMENTS/USE**

*The manufacturer declines any responsibility whatsoever, either civil or criminal, in the case of unauthorised interference or replacement of one or more parts or assemblies on the machine, or if accessories, tools & consumable materials used are different from those recommended by the manufacturer, or if the machine is inserted in a plant system & its proper function is altered.*

#### 2.1.1. Noise Level

The noise level of an idling drill has been measured to be **below 85 dBA**. This complies with the **Australian Occupational Health & Safety (Noise) Regulations 1992**.

Please note that peak impulse noise levels will be experienced due to variables including drill characteristics, type, & condition. This will also vary accordingly depending on the size & type of sample being drilled. Under these circumstances, management should make available to the operator(s) the appropriate hearing protection equipment as prescribed under the above-stated act.





### 2.1.2. Power Supply

The 415/240V power supply requirements for this machine are of a high level & unauthorised interference and or inadequate maintenance could result in a situation that could put the operator at risk. A **qualified** electrical engineer should always be assigned to maintain & repair the system.



## 2.2. General Requirements

### Lighting

Insufficient lighting during the operation of the drill unit would constitute a safety hazard for the people concerned. For this reason, the user of the machine must provide adequate lighting in the working area to eliminate areas of shadow, whilst also preventing dazzling illumination sources (Reference standard **ISO 8995 - 2002 'Lighting of Indoor Workplaces'**).

### Connection

Check that the power supply cables, compressed air supply (if applicable) and/or coolant system complies with, & are operating within the acceptable range of the drill capabilities.

**Faulty, damaged or worn components must be replaced immediately.**

### Earthing Systems

The installation of the earthing system must comply with the requirements stated in the: **IEC Standards Part 195: Earthing & Protection Against Electric Shocks 1998.**

### The position of the Operator

The user controlling the machine drill operations must be positioned as shown in *figure 4* below.



**Figure 4.** Correct Position for Operating Drill Unit



## 2.3. Advice for the Operator



**Protective eyewear or goggles must be worn at all times** while attending & operating the drill.



**Do not attempt to operate the machine unless all safety guards are in operation.**



Ensure that **hands & arms are kept clear of the drilling zone** when the machine is operating.



**Do not wear loose clothing** with long sleeves & oversized gloves, bracelets, necklaces or any other loose object that may become entangled in the machine's tooling bit during drilling. Long hair must be tied back or placed in a hair net.



**Always disconnect the power supply to the machine before carrying out any maintenance work or adjustments.** This includes cases of abnormal operations of the machine.



Any maintenance work performed on the hydraulic, pneumatic or coolant systems must be carried out only after the pressure in the system has been released.



The operator **MUST NOT** conduct any risky operations or those not required for the drilling in course (e.g. remove swarf shavings from the machine while drilling).  
**Never move the drill while the machine is operating.**



**Always keep the workplace as clean as possible.**  
Remove equipment, tools or any other objects from the drilling zone.



**Support the workpiece** to prevent it falling or jamming during the drilling cycle.



**If the drill bit is jammed during a drill, activate the emergency stop function immediately.** Do not continue forcing the drill bit through. This could damage the drill, the specimen or be a cause for potential injury to the operator.



**Always turn off the machine before carrying out any repair work.** Consult the **Brobo Group** Engineering Department in the country in which the machine was initially purchased.

## **2.4. Machine Safety Devices**

This product & maintenance manual is not purely intended as a guide for the usage, operation, & maintenance of the drill unit in a strict production environment; it is instead an instrument to providing information on how to use the machine correctly & safely. The following standards listed in section 2.4.1, which are applicable to the **Brobo Group 3M Drill**, are those specified by the EEC Committee that governs the safety of machinery, health & safety at work, personal protection & safeguarding of the work environment. In addition, the drill also complies with the **Australian Standards** regarding the safeguarding & general requirements for electrical equipment.

### **2.4.1. Reference Standards**

#### **MACHINE SAFETY**



- *EEC Directive No. 98/37/CE - Machines Directive*
- *EEC Directive No. 91/368 - 94/68 - Amends sections of EEC Directive No. 98/37/CE relating to machine safety*
- *EEC Directive No. 73/23 - Low Voltage Directive*
- *AS4024.1 - 1996 - Safeguarding of Machinery*

#### **HEALTH & SAFETY AT WORK**

- *AS3100 - 2002 - General Requirements for Electrical Equipment*
- *OH. & S. 1995.81/1995 - Compliance References*
- *EEC Directive No. 80/1107; 83/477; 86/188; 88/188; 88/642 - Protection of workers against risks caused by exposure to physical, chemical & biological agents in the workplace*
- *EEC Directive No. 73/23 & Special EEC Directives No. 89/654; 89/655 - Improvements in health & safety at work*



## CHAPTER 3 - Main Functions & Operation of the Machine

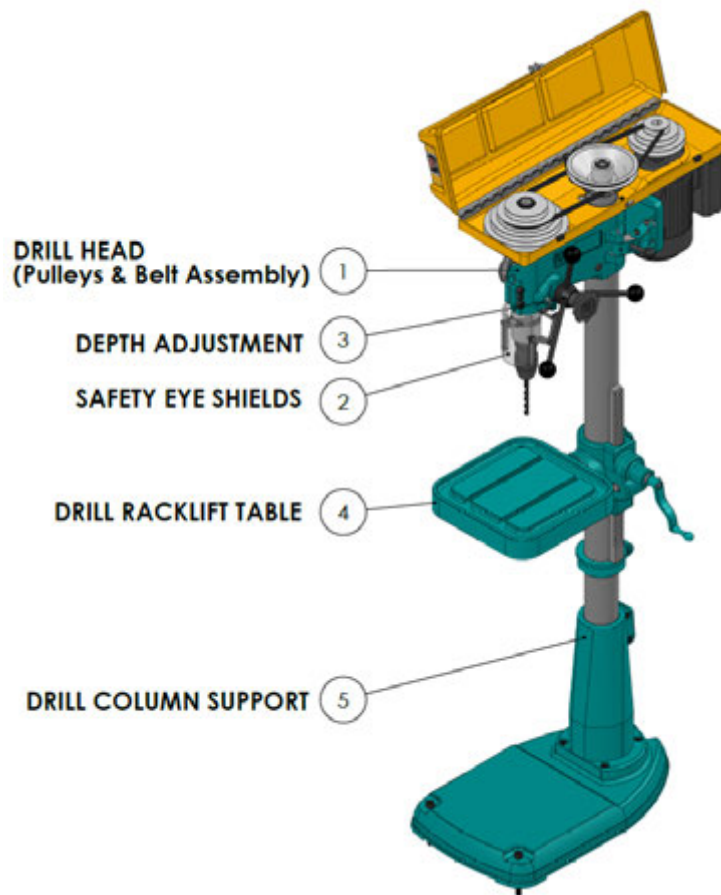

Figure 5. 3M Drill Main Figures

### 3.1.1. Drill Head (Pulley & Belt Assembly)

The full set of the motor drive, intermediate & quill pulleys are all housed within the protective drill guard cover. Facing the front of the drill unit, the spindle speed setting is located on the right-hand side of the cover, beneath the locking mechanism. To change the spindle speed settings, the user must manually change the V-belt positions as shown in the black panel.



Figure 6. Drill Head

### 3.1.2. Safety Eye Shields

As the name suggests, the safety eye shield should be lowered into position prior to drilling to prevent any swarf dislodging in the direction of the user.



Figure 7. Safety Eye Shields

### 3.1.3. Depth Adjustment

Situated beneath the 3-pronged handle boss is the depth adjustment gauge. Using the gauge & the scale indicator shown on the left-hand side of the drill, the operator can manually set the desired depth for a drill hole & lock its position.



Figure 8. Depth Adjustment

### 3.1.4. Drill Rack lift Table

Available in round or rectangular profile, all workpiece is fastened to the rack lift table using a standard mechanical vie (not provided). The rack lift can be adjusted up or down via the rack handle, to obtain optimum user working height.

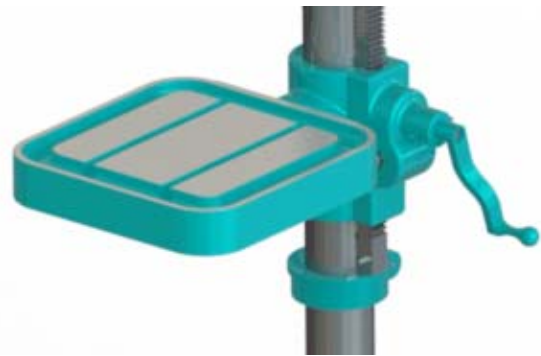

Figure 9. Racklift Table

### 3.1.5. Drill Column Support

Prior to usage, ensure that the column support is securely fastened to the ground using the 3 x M16 bolt holes provided.

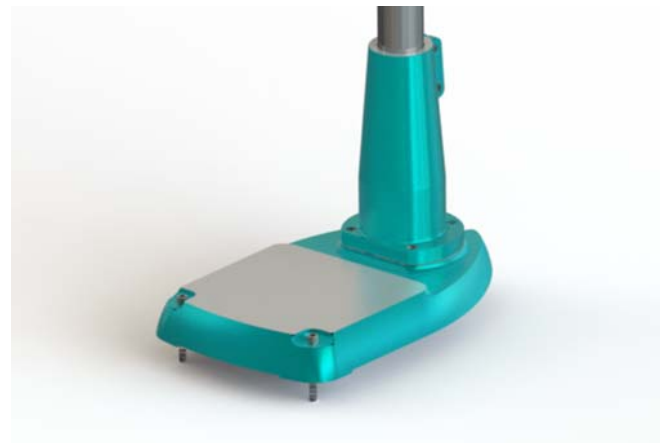

Figure 10. Drill Column Support  
(Floor Mounts)





### **3.2. Preparation for Operation**

The following procedure is recommended for the correct drilling using the **Robo Group 3M Drill**



#### **WARNING – SAFETY GEAR**

*Protective clothing, safety glasses and gloves should **always** be worn while loading parts, operating the machine, or undertaking any maintenance work on the machine.*

### **PROCEDURE**

- 1) Clean the workpiece to ensure it is free of any grit, swarf or flammable substances. It is highly recommended that a solvent is used to remove any residue while ensuring the solvent is inflammable and non-toxic.
- 2) Prior to drilling, clear the drill & the work area around the workpiece of any swarf or/and tools to minimise the likelihood of the user getting injured during the drilling operation.
- 3) Load the workpiece into the mechanical vice (sold separately), located on the rack lift, & fastened workpiece securely. Loosen the rack lift & adjust the height & horizontal position. Once you have positioned the workpiece into the desired location, relock the rack lift assembly.
- 4) Check that the correct speed drill speed setting is selected, & the safety eye shield is directly positioned to deflect swarf & any dislodged particles.
- 5) Turn the machine on. Proceed by slowly drilling into the workpiece until a guide indent is created. Steadily increase the feed rate of drilling by applying a constant yet steady force on the feed handle until the desired hole depth is reached.
- 6) Reverse the direction of the drill feed until it comes to rest in its start position & turn the drill machine off.

### **3.3. Operation Recommendations**

- To reduce the amount of frictional contact between the drill bit & workpiece, a light coating of oil or lubricant can be applied to the drill bit prior to drilling.
- Do not force the drill bit through the workpiece as this significantly reduces the lifespan of the bit, as well as increasing the risk of the bit bending and/or breaking & injuring the operator.
- When drilling through larger hole diameters through thick materials, it is advisable to split the drilling operation into two or three stages, starting from drilling a smaller hole size & increasing it until the desired final hole size.



#### **WARNING - JAMMING**

*If the drill jams during a drill, engage the **EMERGENCY STOP** immediately. Remove the part, check that the drill bit is not damaged and if need be, replace the drill bit.*

# CHAPTER 4 - Drawings, Layouts, Assembly & Spare Parts

---

## 4.1. Spare Parts

Please find below for most commonly replaced spare parts. These listed parts draw reference to components found predominantly on the rack lift assembly & drill column support. Should you require a spare part that you are not familiar with, or not shown in Chapter 4, please contact [Brobo Group Engineering](#) department.

PART NUMBER	SPARE PART DESCRIPTION
1132010	BASE, FLOOR TYPE
2112010	COLUMN SUPPORT ( use with Floor Base)
2114060	COLUMN, FLOOR (Solid, 1220mm)
2114310	COLUMN, BENCH (Solid, 767mm)
2122020	COLUMN CLAMP (includes 1042000 & 2124050)
2121310	RACKLIFT ASSEMBLY, COMPLETE (Floor Type)
1041080	RACKLIFT ASSEMBLY, COMPLETE (Bench Type)
2114010	RACK
2114020	SPINDLE WORM
2114040	WORMWHEEL SPINDLE (Shaft)
2111170	SPINDLE & EXTENSION ASSEMBLY
2121230	QUILL ASSEMBLY
2125200	MOTOR (0.75kW, 1HP, 1PH, TEFC)
2125180	MOTOR (0.75kW, 1HP, 3PH, TEFC)

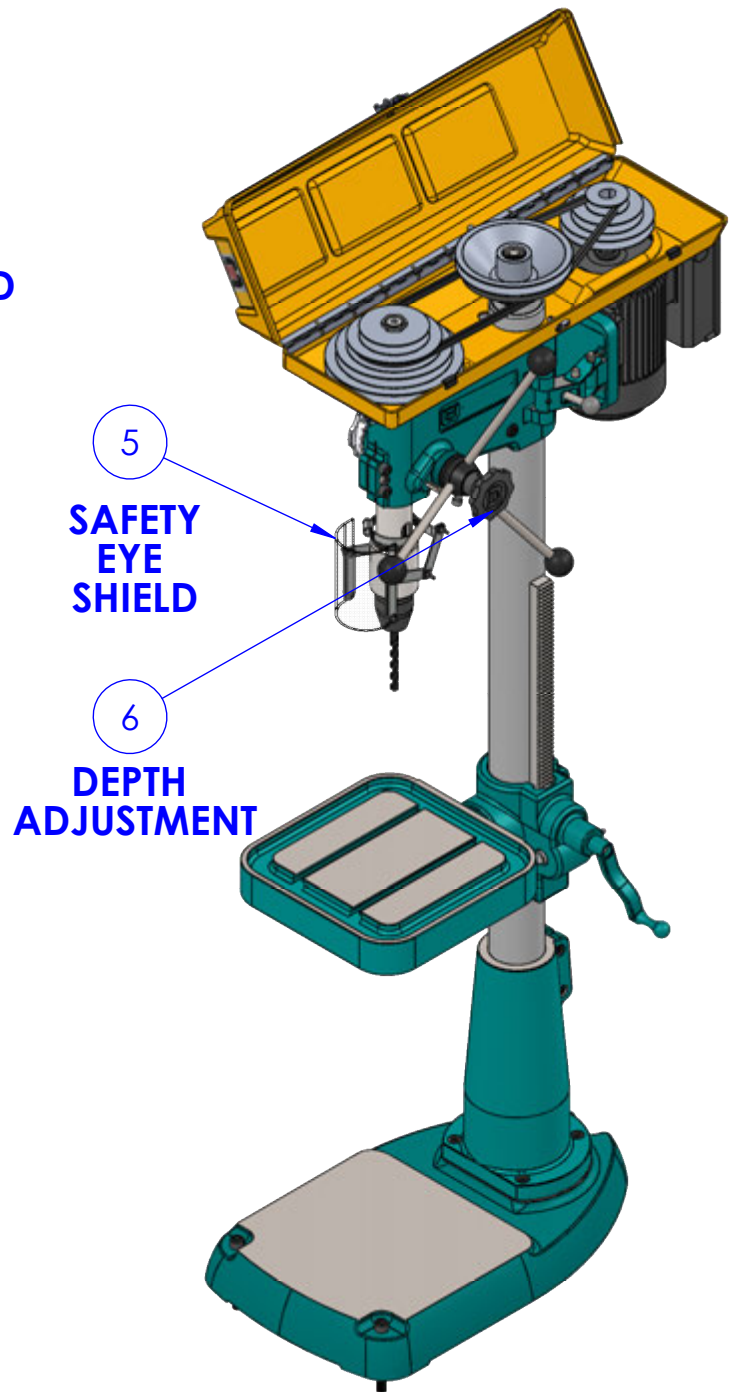
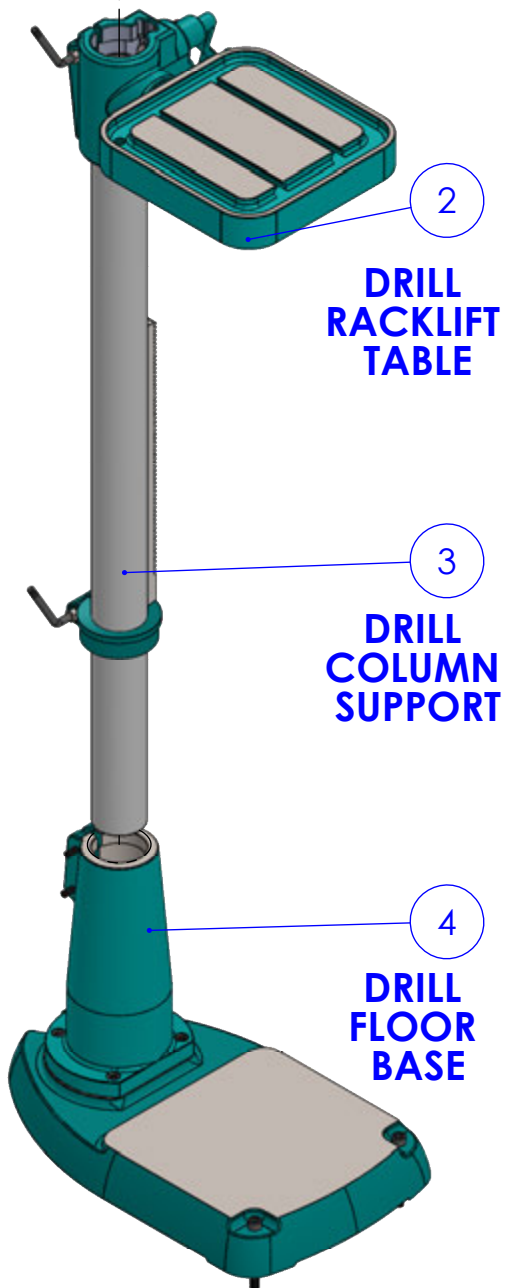
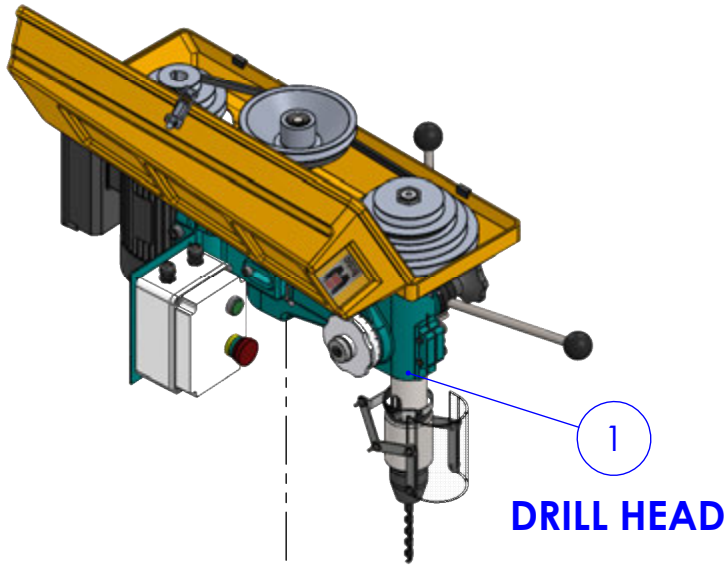

**3M DRILL**



**BROBO GROUP**

Address : 8 Fowler Rd, Dandenong VIC 3175  
<https://brobo.com.au/>

DRW NO.

**3M.0010**

DRAWN BY

ANH

TITLE:

**3M DRILL ASSEMBLY**

ISSUED DATE

18.10.2019

SCALE:NTS

A4

SHEET 1 OF 1



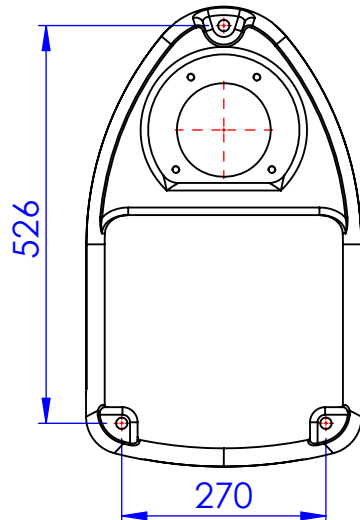
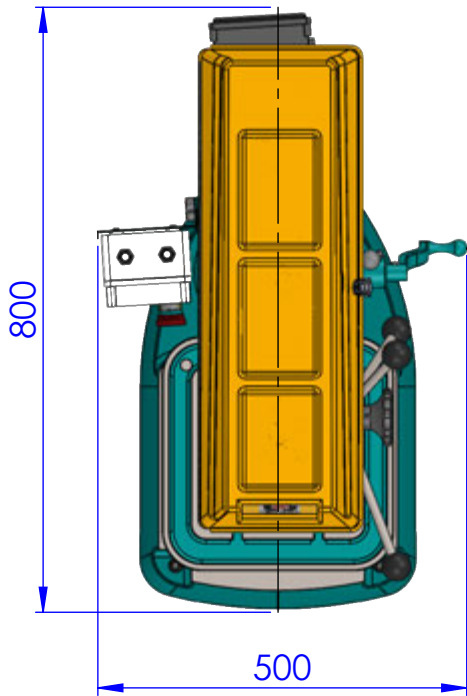

**ANCHOR HOLE LOCATION**

MINIMUM 600MM ALL AROUND SAFE SPACE FOR OPERATING ZONE

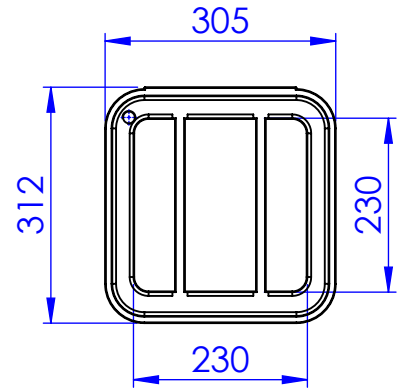

**TABLE SIZE**

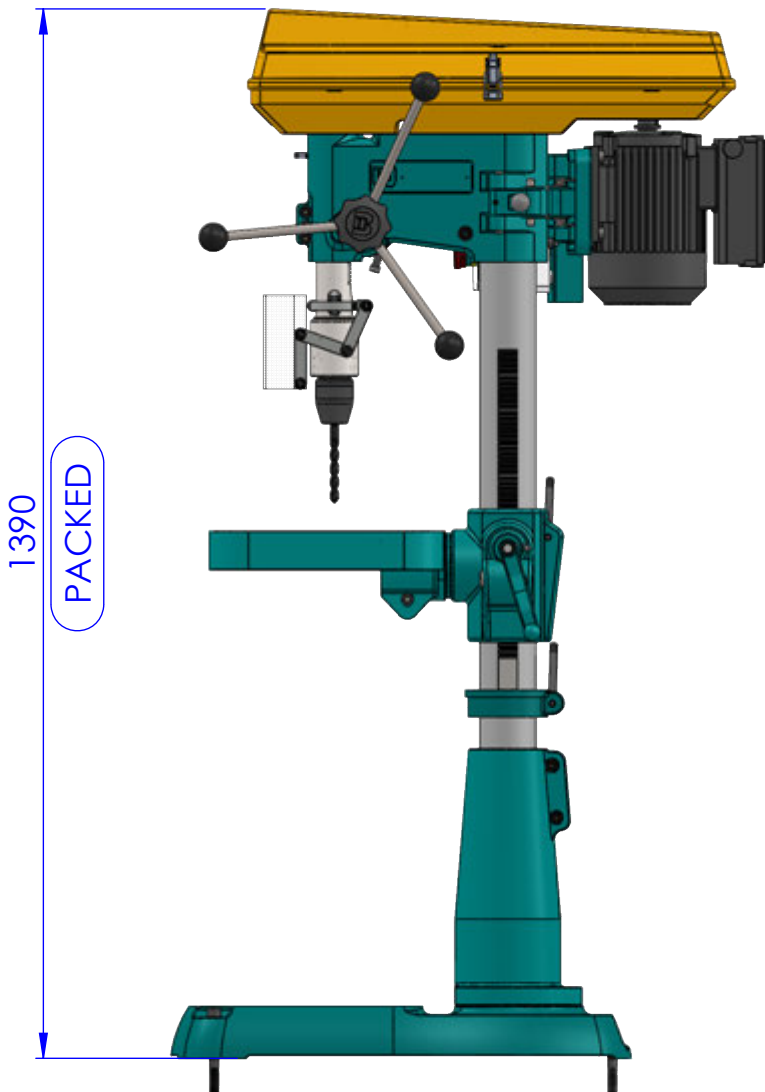

1390  
PACKED

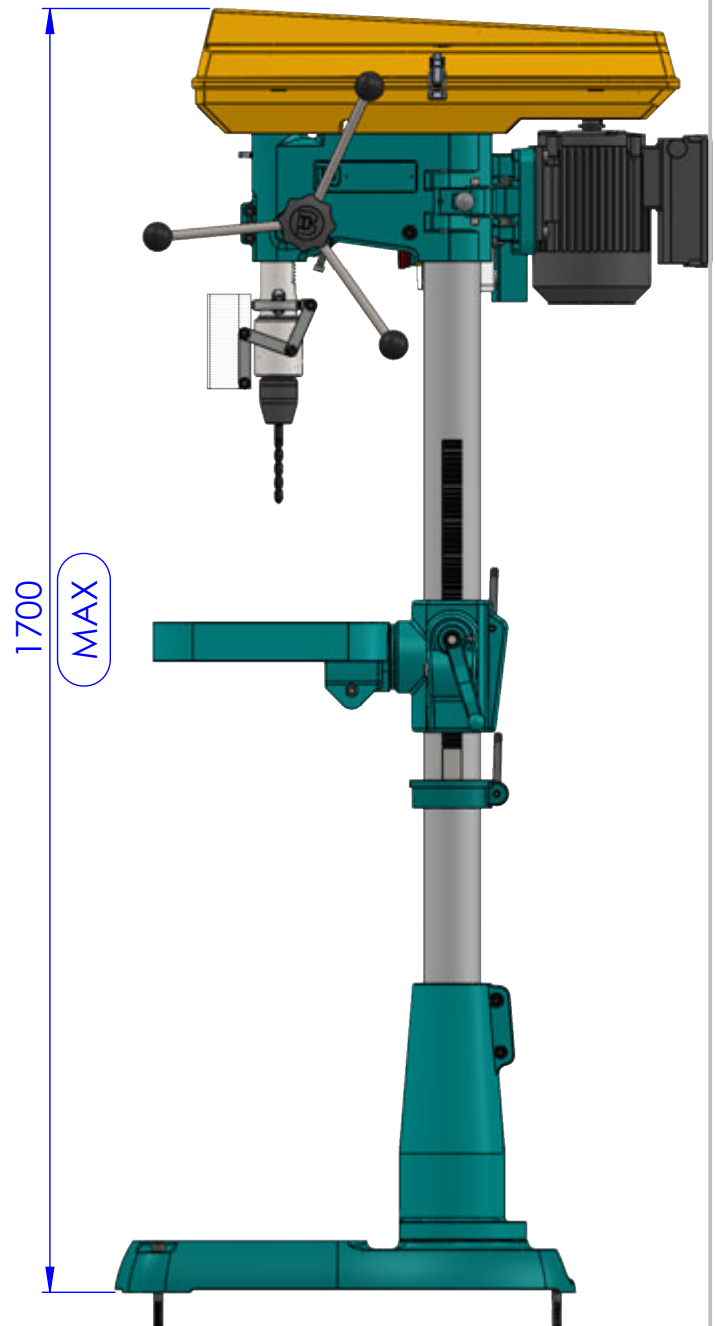

1700  
MAX



**BROBO GROUP**

Address : 8 Fowler Rd, Dandenong VIC 3175  
<https://brobo.com.au/>

DRW NO.

**3M.0020**

DRAWN BY

ANH

TITLE:

**3M DRILL FLOOR MOUNT**

ISSUED DATE

18.10.2019

SCALE:NTS

A4

SHEET 1 OF 1

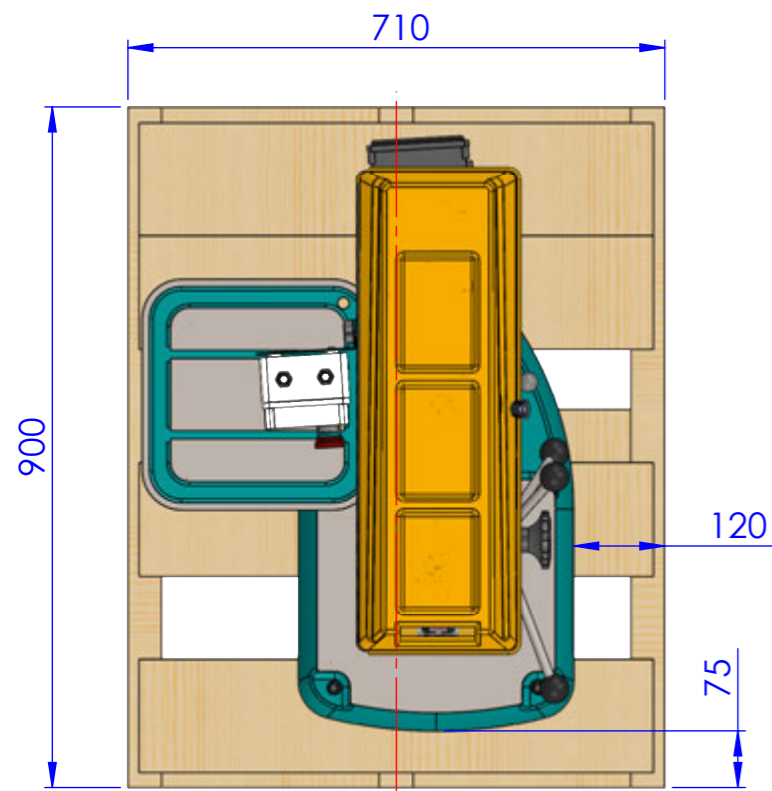
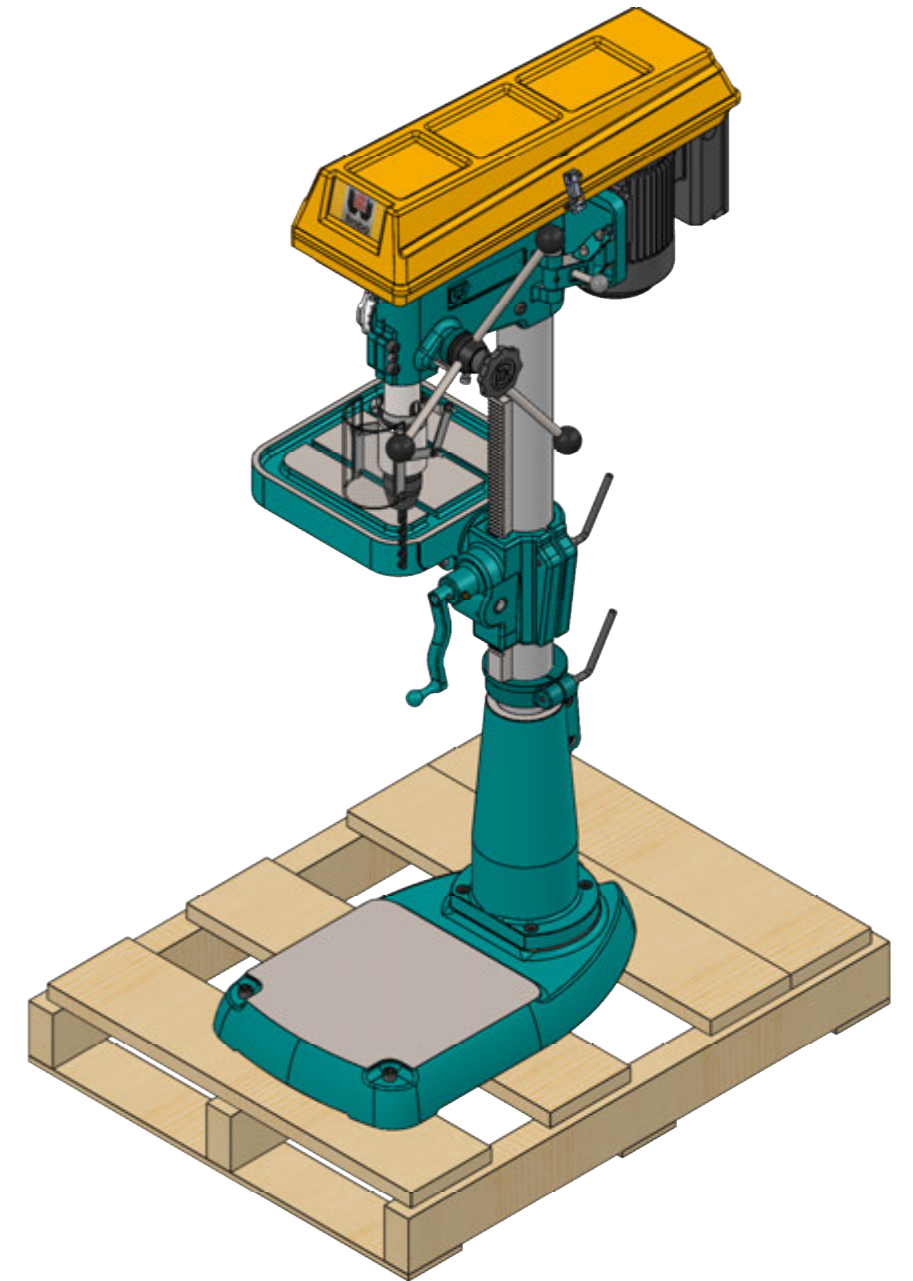
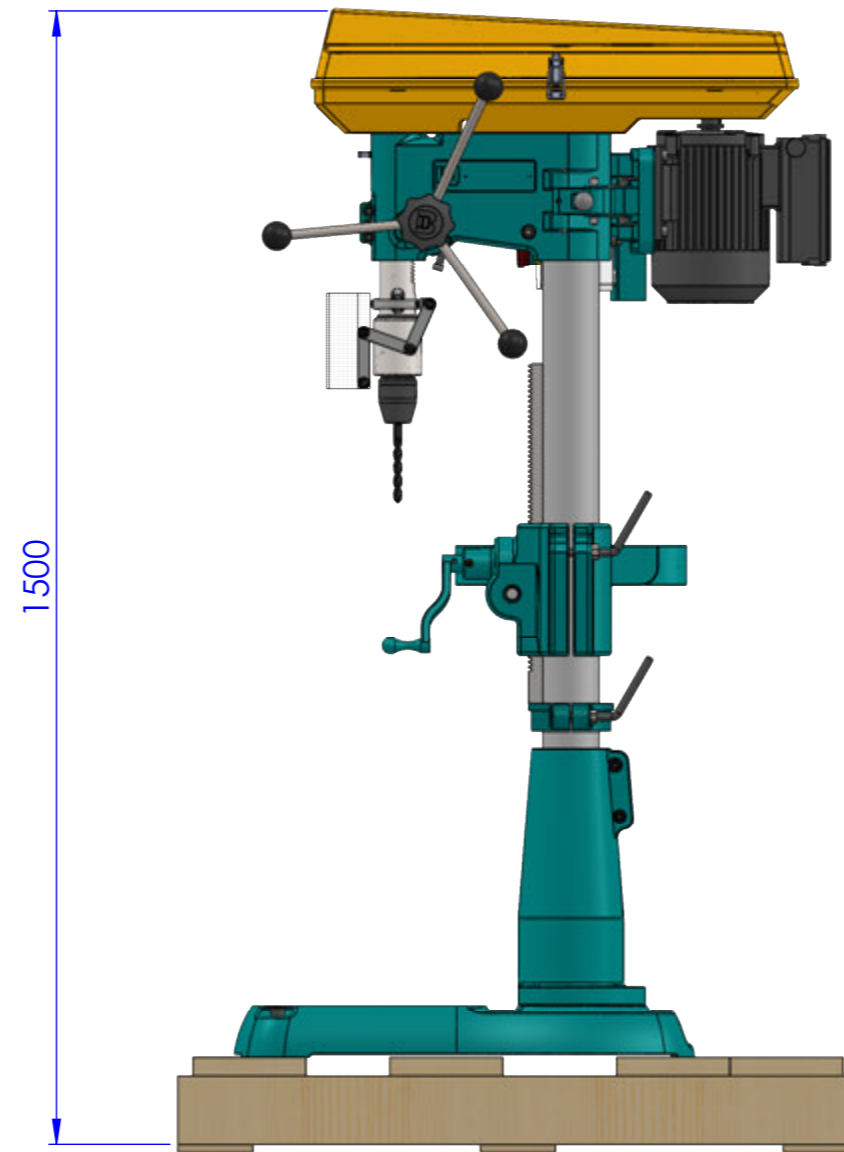

TABLE TO BE ROTATED 90°  
FOR STRAPPING PURPOSE



TOLERANCES ON DIMENSIONS ARE METRIC	SIZE	TO MATCH	CAST*	GRADE	RA (µm)	GRADE	RA (µm)
DIMENSIONS ARE IN MILLIMETERS	6 mm	±0.1	±0.5	N1	0.025	N7	1.6
ANGULARITY TOLERANCE < ±0°10'	30 mm	±0.2	±0.5	N2	0.05	N8	3.2
CONCENTRICITY 0.1 mm	100 mm	±0.3	±1.5	N3	0.1	N9	6.3
REMOVE ALL BURRS & SHARP EDGES	300 mm	±0.5	±2.0	N4	0.2	N10	12.5
BY 0.3 x 45°	1000 mm	±0.6	±3.0	N5	0.4	N11	25.0
UNLESS OTHERWISE STATED	2000 mm	±1.2	±5.0	N6	0.8	N12	50.0

DRAWN BY ANH  
DATE 09.12.2019

MATERIAL: -

WEIGHT:

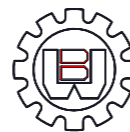

**BROBO GROUP**  
Address : 8 Fowler Rd, Dandenong VIC 3175  
<https://brobo.com.au/>

TITLE:

**3M DRILL  
PACKAGING**

DO NOT SCALE DRAWING SCALE:1:10 REVISION 0

DWG NO.

**8815040**



SHEET 1 OF 1 A3

MINIMUM 600MM ALL AROUND SAFE SPACE FOR OPERATING ZONE

ITEM NO.	PART NUMBER	DESCRIPTION	QTY.
1	1132010	Drill Floor Base (2019)	1
2	8705300	Socket Head Cap Screw M12x100	2
3	8705280	Socket Head Cap Screw M12x65	1
4	8725500	Socket Head Cap Screw M10x35	4
5	2442160	Column Support (Bench)	1
6	2114310	Drill Column (Bench)	1
7	2114010	DRILL Table Racklift	1

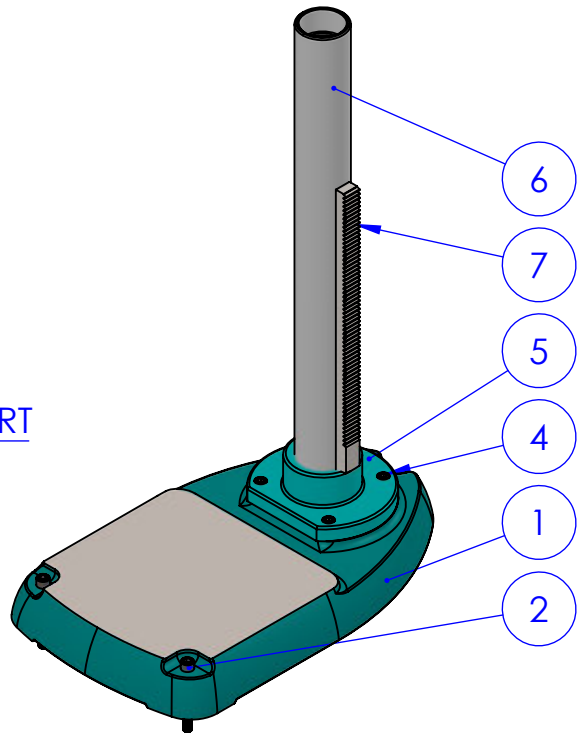
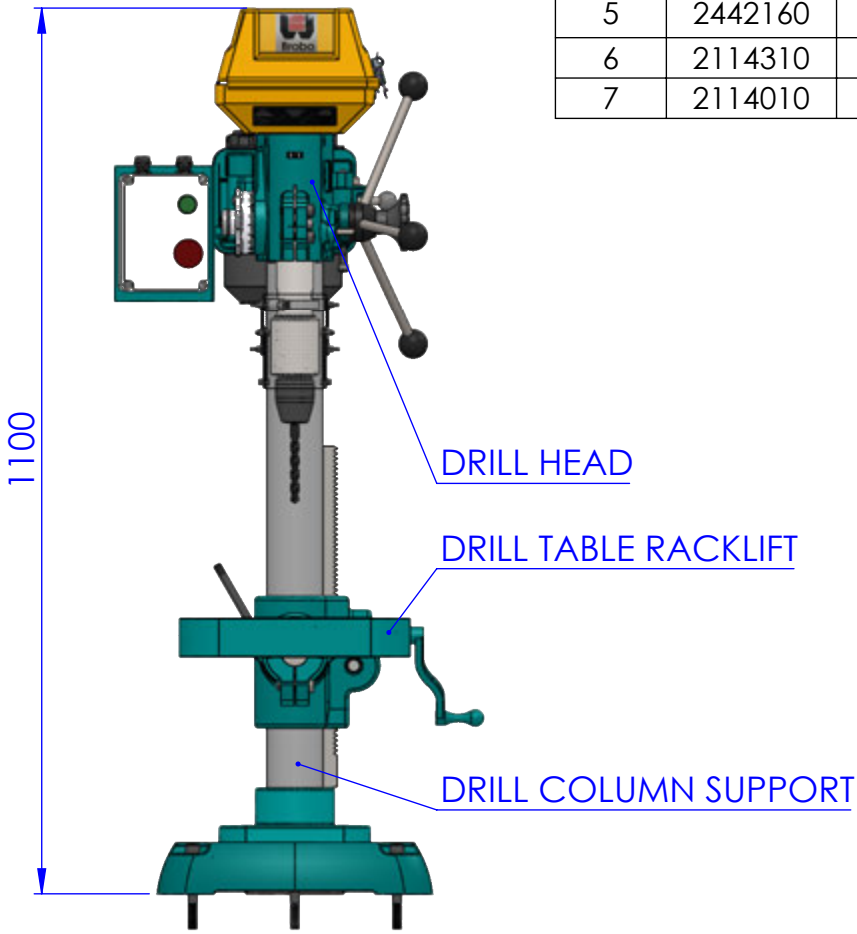

**DRILL COLUMN SUPPORT ASSEMBLY**

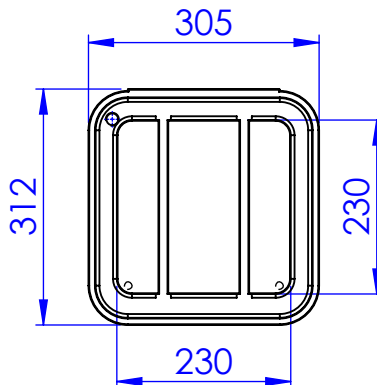
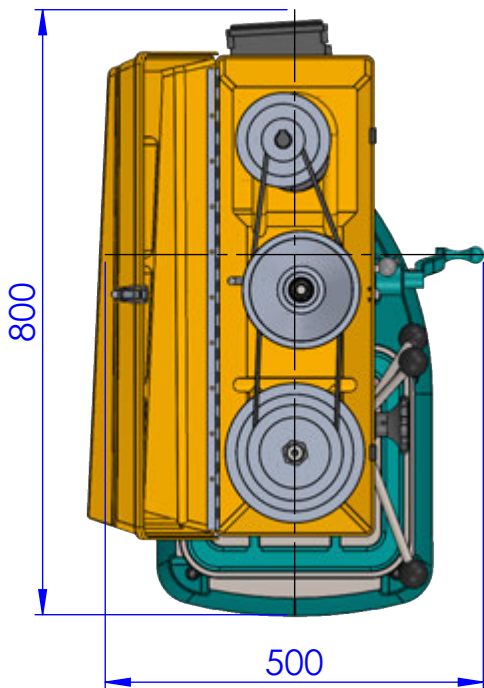

**TABLE SIZE**



**BROBO GROUP**

Address : 8 Fowler Rd, Dandenong VIC 3175  
<https://brobo.com.au/>

DRW NO.

**3M.0030**

TITLE:

**3M DRILL BENCH MOUNT**

A4

DRAWN BY

ANH

ISSUED DATE

18.10.2019

SCALE:NTS

SHEET 1 OF 1

ITEM NO.	PART NUMBER	DESCRIPTION	QTY.
1	2121230	3M Drilli Quill Assembly	1
2	2111170	Spindle & Extension Assembly	1
3	1041170	Pulley Intermediate Drive Assembly	1
4	DSCM	Drill Switch Control & Motor Assembly	1
5	DHA	Drill Handle Assembly	1
6	2122190	Dial Assembly	1
7	1051190	Drill Belt Guard Assembly	1
8	1031570	Drill Chuck Guard Assembly	1
9	2121180	Drill Toggle	1

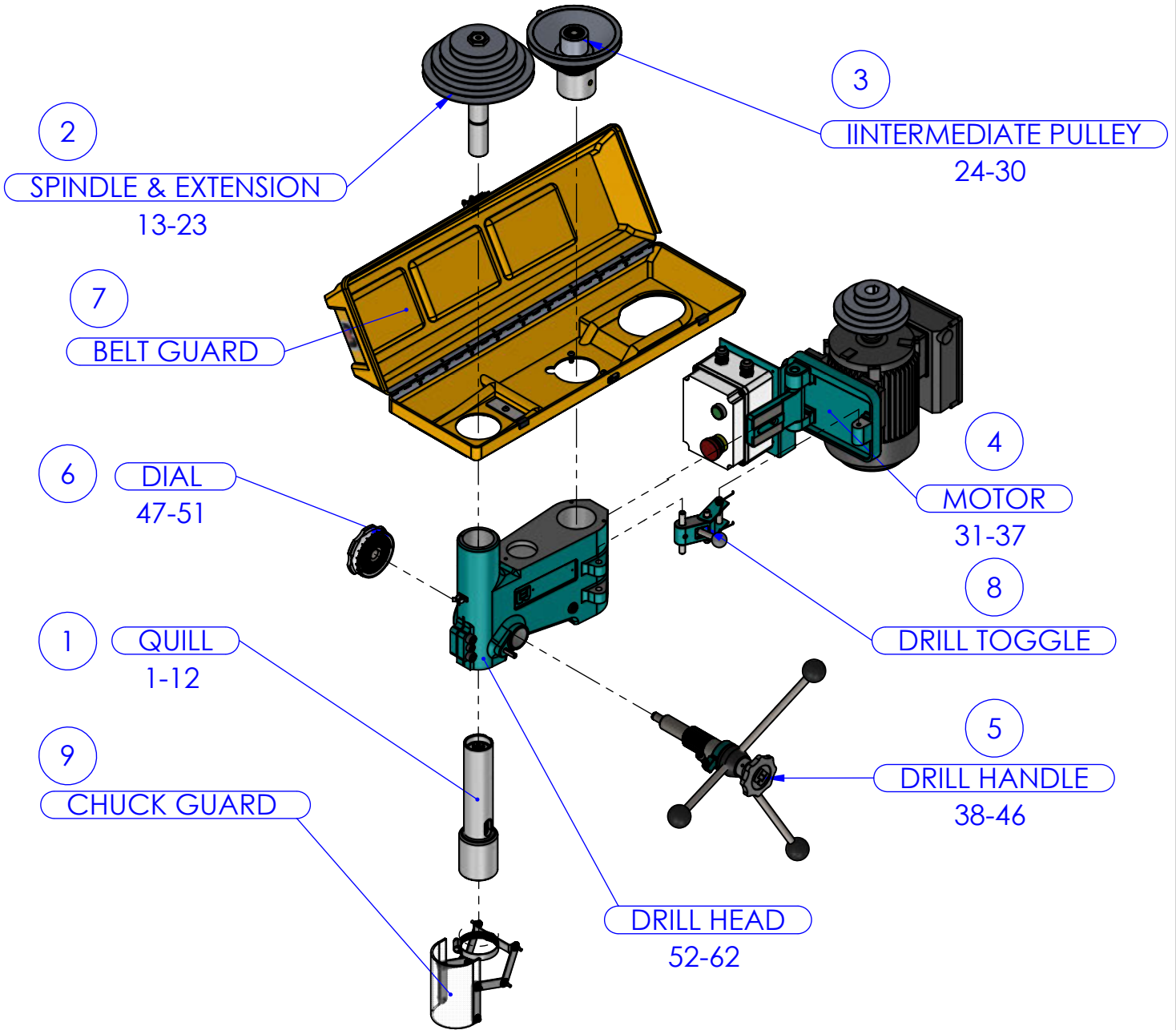

## DRILL HEAD SUB-ASSEMBLY

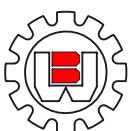

**BROBO GROUP**

Address : 8 Fowler Rd, Dandenong VIC 3175  
<https://brobo.com.au/>

DRW NO.

**M3.0040**

TITLE:

**3M DRILL HEAD  
ASSEMBLY**

A4

DRAWN BY

ANH

ISSUED DATE

04.07.2019

SCALE:NTS

SHEET 1 OF 3

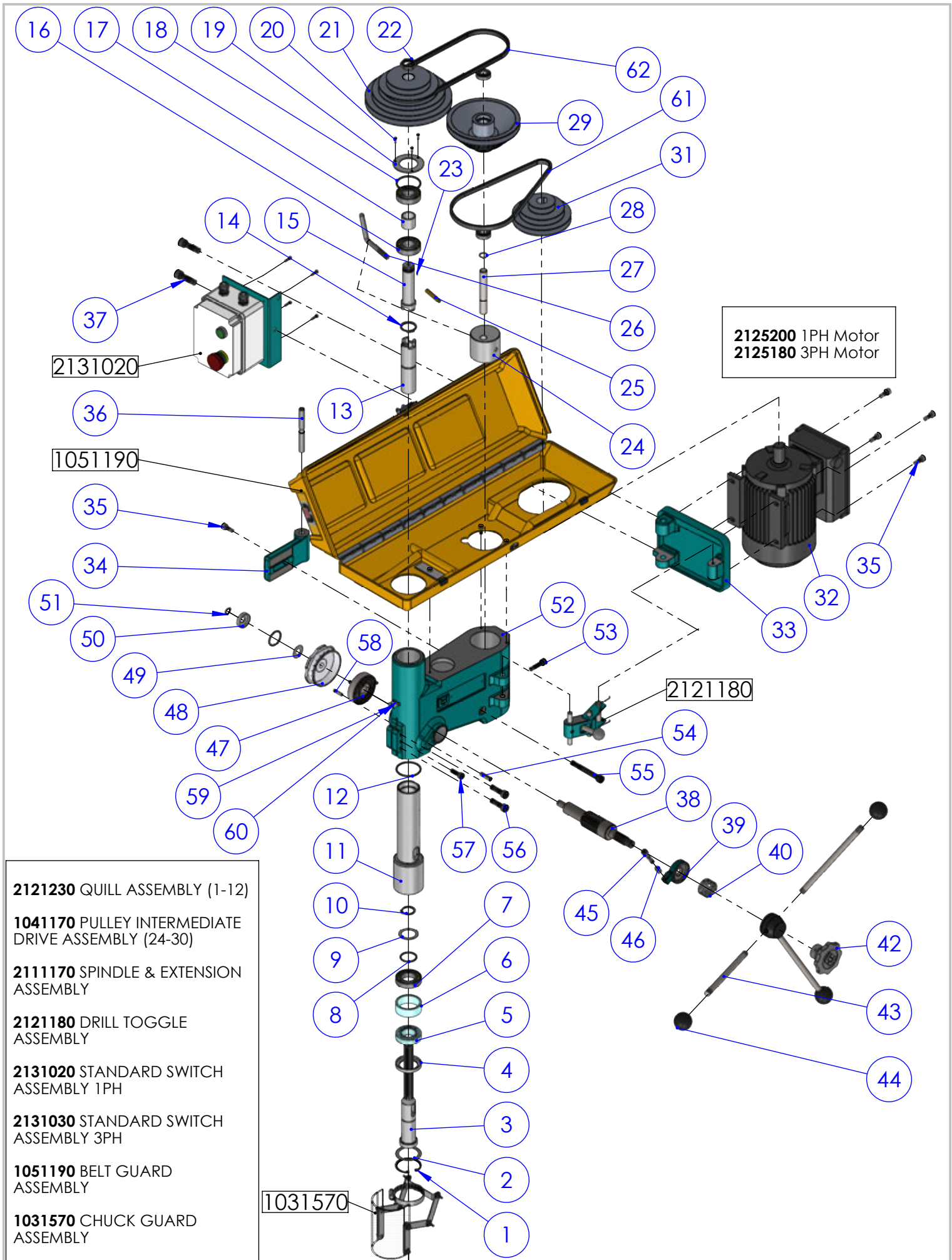

2125200 1PH Motor  
2125180 3PH Motor

- 2121230 QUILL ASSEMBLY (1-12)
- 1041170 PULLEY INTERMEDIATE DRIVE ASSEMBLY (24-30)
- 2111170 SPINDLE & EXTENSION ASSEMBLY
- 2121180 DRILL TOGGLE ASSEMBLY
- 2131020 STANDARD SWITCH ASSEMBLY 1PH
- 2131030 STANDARD SWITCH ASSEMBLY 3PH
- 1051190 BELT GUARD ASSEMBLY
- 1031570 CHUCK GUARD ASSEMBLY

ITEM NO.	PART NUMBER	DESCRIPTION	QTY.	ITEM NO.	PART NUMBER	DESCRIPTION	QTY.
1	2115330	Internal Circlip (55mm)	1	38	2114070	Drill Pinion	1
2	2113030	Shim Quill OD=ø55 ID=ø41 x 0.03	1	39	1034020	Drill Handle Stop	1
3	2124330	Drill Spindle 3M	1	40	1035010	Spring	1
4	2114150	Bearing Spacer	1	41	1044030	Drill Handle Boss	1
5	2115080	Taper Roller Bearing 55x30x17 HR32006	1	42	1031360	Handnut	1
6	2114160	Bearing Spacer Sleeve ø55xø48x20.2	1	43	2124350	Drill Capstan Spoke (3M)	3
7	8115030	Bearing 6006 55x30x13	1	44	1045020	Knob 38mm	3
8	2115290	O-Ring (ID=ø30mm)	2	45	8726130	Socket Head Cap Screw M8 x 40	1
9	1043200	Spindle Washer	1	46	1035030	Drill Stop Screw Spring	1
10	8115070	External Circlip 30mm	1				
11	2124340	Drill Quill Sleeve	1				
12	2115060	O-Ring ID 47.6mm	1				

ITEM NO.	PART NUMBER	DESCRIPTION	QTY.
13	2124110	Drill Drive Sleeve 3M	1
14	2125070	External Circlip 35.6x30.3	1
15	2124120	Drill Castellated Pulley Spindle	1
16	2115230	Bearing 6205	2
17	2124130	Bearing Spacer ø30xø25x26	1
18	5125340	O-Ring 50x3.5	1
19	2123040	Bearing Cap	1
20	8735020	Pan Head Screw M3x10	3
21	2122060	Drill Head Pulley 4 Step	1
22	1044120	Thin Hex Nut M25x1	1
23	1035130	Woodruff Key No.3	1

ITEM NO.	PART NUMBER	DESCRIPTION	QTY.
24	1044190	Intermediate Drive Block	1
25	1034230	Drill Plunger	1
26	1044210	Locking Handle	1
27	1044200	Intermediate Drive Spindle	1
28	1045810	External Circlip 15mm	1
29	1045290	Intermediate Drive Pulley	1
30	1045280	Intermdiate Bearing (6002-2Z)	2

ITEM NO.	PART NUMBER	DESCRIPTION	QTY.
31	1045270	Drill Motor Pulley 3 stepx19mm	1
32	2125200	2125200 (1PH) - 2125180 (3PH)	1
33	2122070	Motor Plate	1
34	2122080	Motor Plate Hinge	1
35	8705120	Socket Head Cap Screw M8x20	5
36	2124210	Pivot Pin	1
37	2131020	Switch Assembly 1PH	1

ITEM NO.	PART NUMBER	DESCRIPTION	QTY.
47	2115010	Drill Return Spring	1
48	2122190	Dial (Spring Cover)	1
49	9305350	Shim 50x62x0.1	1
50	2114080	Dial Pressure Cap	1
51	1035070	External Clip	1
52	2122050	Drill Head 3M	1
53	8705140	Socket Head Cap Screw M8x35	1
54	1034060	Roll Pin 8x30	1
55	8705210	Socket Head Cap Screw M10x80	1
56	8725500	Socket Head Cap Screw M10x35	2
57	8705130	Socket Head Cap Screw M8x25	1
58	8705990	Roll Pin 6x24 (Return Spring)	2
59	1035110	Chuck Key Holder	1
60	8725020	Pan Head Philip M3x6	1
61	2115160	Belt Motor, A27	1
62	2115150	Belt Inter. Head A32	1

- [1] 01 - 12 Quill Assembly
- [2] 13 - 23 Spindle & Extension
- [3] 24 - 30 Pulley Intermediate Drive
- [4] 31 - 37 Drill Control & Motor
- [5] 38 - 46 Drill Handle
- [6] 47 - 51 Dial Assembly
- 52 - 62 Drill Head Sub Assembly



**BROBO GROUP**

Address : 8 Fowler Rd, Dandenong VIC 3175  
<https://brobo.com.au/>

DRW NO.

**3M.0060**

TITLE:

**3M DRILL ASSEMBLY**

A4

DRAWN BY

ANH

ISSUED DATE

04.07.2019

SCALE:NTS

SHEET 3 OF 3

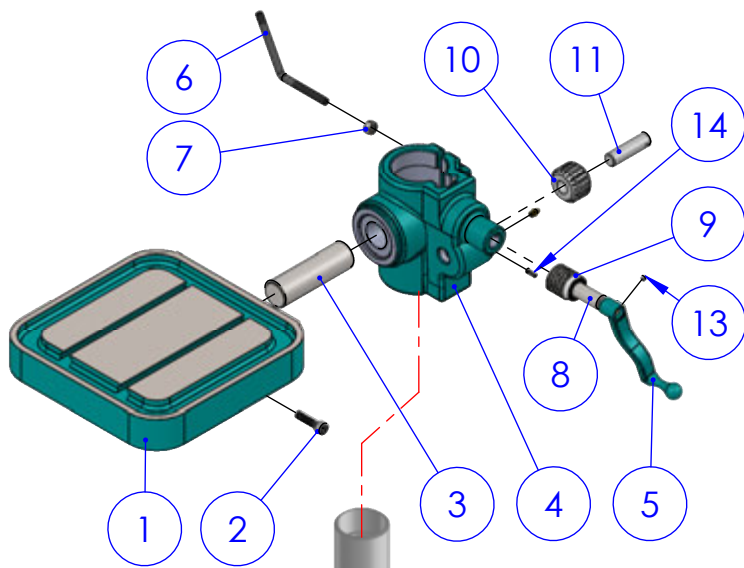

14	8705470	Set Screw M6x16	1
13	8705450	Set Screw M6x6	1
12	9305110	Grease Nipple M8x1.25	1
11	2114040	Wormwheel Spindle (Shaft)	1
10	2114030	Drill Wormwheel	1
9	2035020	51104 NTN Bearing 20x35x10	1
8	2114020	Drill Spindle	1
7	1042000	Hex Nut M10	1
6	2124050	Drill Clamp Handle	1
5	2122160	Drill Crank Handle	1
4	2122030	Drill Table Support	1
3	1044180	Drill Table Support Pin	1
2	8725960	Socket Head Cap Screw M10x40	1
1	2122040	Drill Table	1
ITEM NO.	PART NUMBER	DESCRIPTION	QTY.

**DRILL RACKLIFT TABLE (2121310)**

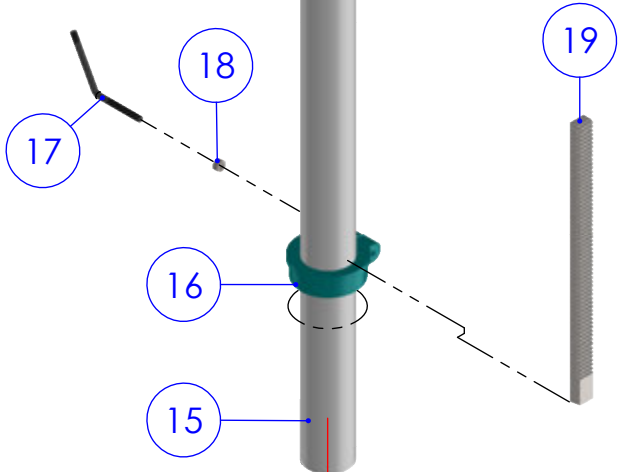

19	2114010	DRILL Table Racklift	1
18	1042000	Hex Nut M10	1
17	2124050	Drill Clamp Handle	1
16	2122020	Drill Column Clamp	1
15	2114060	Drill Column (1220mm)	1
ITEM NO.	PART NUMBER	DESCRIPTION	QTY.

**DRILL COLUMN SUPPORT**

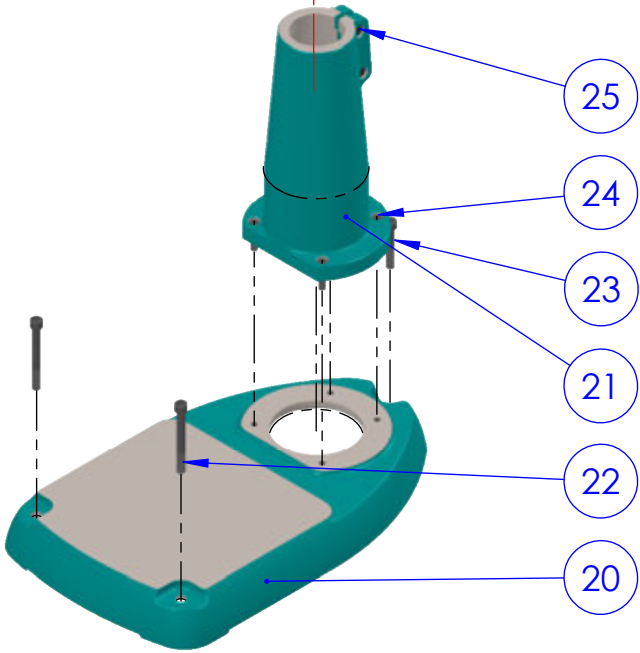

25	8705190	Socket Head Cap Screw M10x50	2
24	8725500	Socket Head Cap Screw M10x35	4
23	8705280	Socket Head Cap Screw M12x65	1
22	8705300	Socket Head Cap Screw M12x100	2
21	2112010	Drill Column Support	1
20	1132010	Drill Floor Base	1
ITEM NO.	PART NUMBER	DESCRIPTION	QTY.

**DRILL FLOOR BASE**



**BROBO GROUP**  
 Address : 8 Fowler Rd, Dandenong VIC 3175  
<https://brobo.com.au/>

DRW NO. **3M.0070**  
 DRAWN BY ANH

TITLE: **3M DRILL FLOOR COLUMN ASSEMBLY**

A4

ISSUED DATE 10.12.2019 SCALE:NTS SHEET 1 OF 1

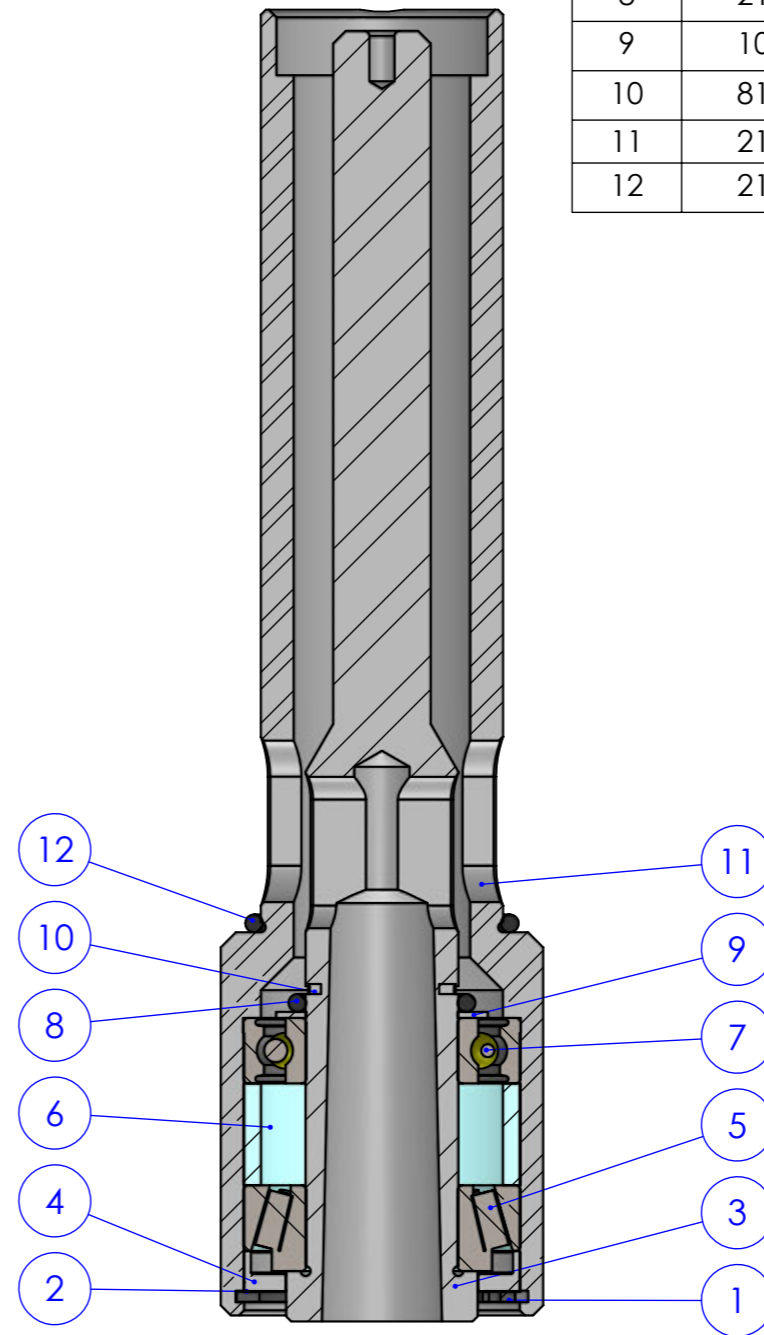
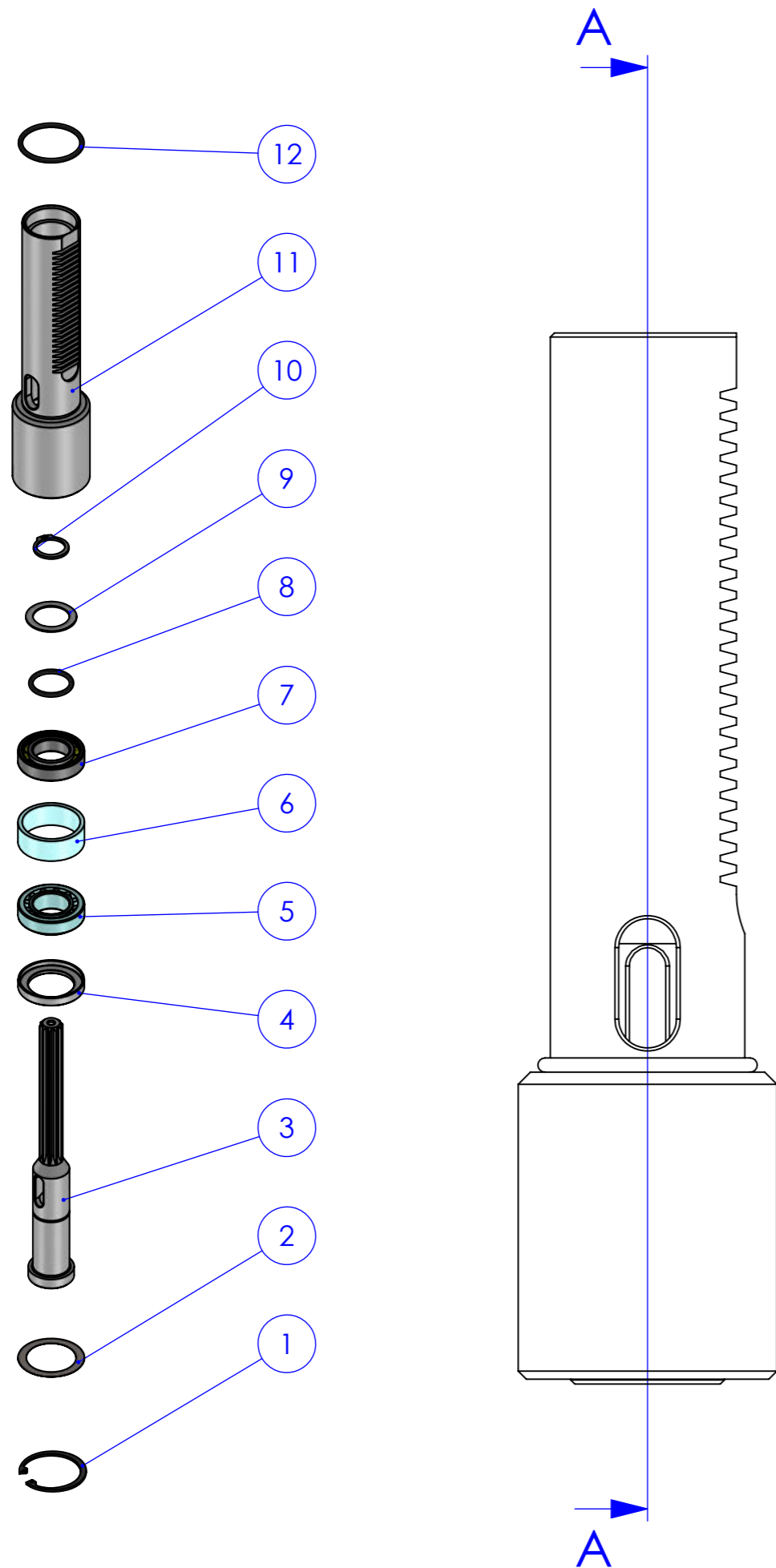

**SECTION A-A**

ITEM NO.	PART NUMBER	DESCRIPTION	QTY
1	2115330	Internal Circlip (55mm)	1
2	2113030	Shim Quill OD=ø55 ID=ø41 x 0.03	1
3	2124330	Drill Spindle 3M	1
4	2114150	Bearing Spacer	1
5	2115080	Taper Roller Bearing 55x30x17 HR32006	1
6	2114160	Bearing Spacer Sleeve ø55xø48x20.2	1
7	8115030	Bearing 6006 55x30x13	1
8	2115290	O-Ring (ID=ø30mm)	1
9	1043200	Spindle Washer	1
10	8115070	External Circlip 30mm	1
11	2124340	Drill Quill Sleeve	1
12	2115060	O-Ring ID 47.6mm	1

ALL RIGHTS RESERVED. THIS DRAWING MAY NOT BE REPRODUCED OR TRANSMITTED IN ANY FORM OR BY ANY MEANS IN PART OR IN WHOLE WITHOUT THE WRITTEN PERMISSION OF BROBO GROUP PTY LT

DRAWN ANH  
DATE 04.07.2019  
MATERIAL:  
WEIGHT:

UNLESS OTHERWISE SPECIFIED:  
DIMENSIONS ARE IN MILLIMETERS  
SURFACE FINISH:  
TOLERANCES:  
LINEAR:  
ANGULAR:

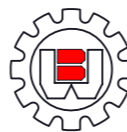

**BROBO GROUP**  
Address : 8 Fowler Rd, Dandenong VIC 3175  
<https://brobo.com.au/>

TITLE:

**3M DRILL QUILL ASSEMBLY**

DO NOT SCALE DRAWING SCALE:1:1.5 REVISION 0

DWG NO.

**2121230**



SHEET 1 OF 1 A3



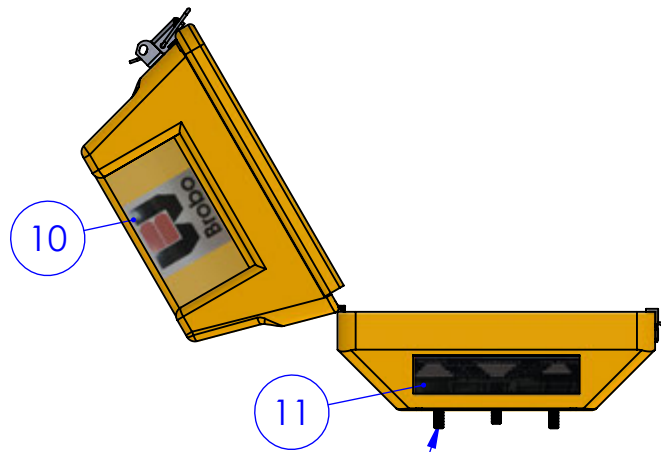

TO DRILL HEAD  
PART NO. 2122050

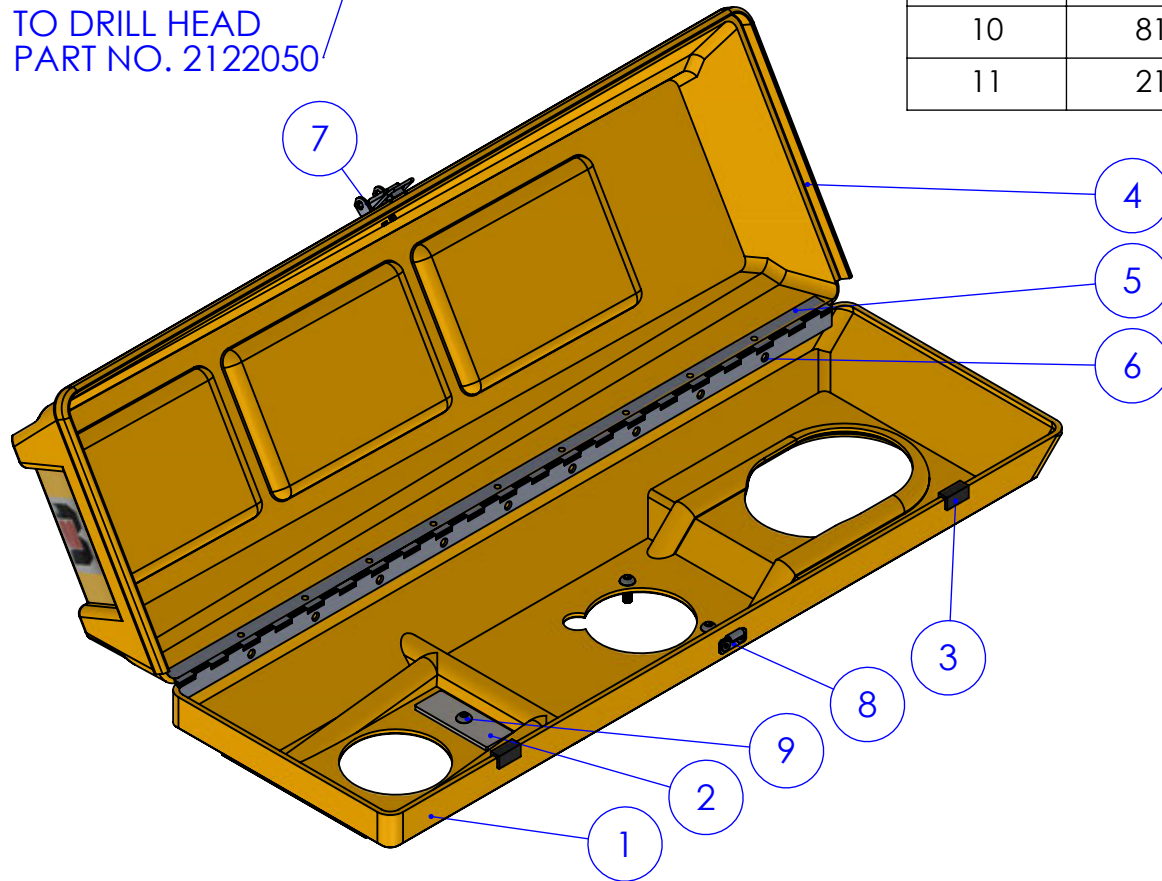

## DRILL BELT GUARD ASSEMBLY

ITEM NO.	PART NUMBER	DESCRIPTION	QTY.
1	1035370	Drill Belt Guard Bottom	1
2	1604100	Plate Clamp	1
3	1034250	Rubber Buffer	2
4	1035360	Drill Belt Guard Cover	1
5	1034340	Piano Hinge	1
6	8715930	Rivet	-
7	1015240	Latch	1
8	1105050	Catch Plate	1
9	8726100	Button Head Socket Screw M6x16	3
10	8115090	Brobo Logo	1
11	2125140	Drill Speed Chart	1



## TOGGLE ASSEMBLY

ITEM NO.	PART NUMBER	DESCRIPTION	QTY.
1	2122090	Motor Plate Toggle	1
2	2124170	Drill Toggle Head Pivot Pin	1
3	8705460	Set Screw Cup Point M6x8	1
4	2134200	Drill Toggle Link	2
5	2124180	Drill Toggle Link Pin	2
6	2115100	Drill Toggle Top Spring	1
7	2125090	Toggle Link External External Circlip 10mm	2
8	2124190	Drill Toggle Handle	1
9	1045200	Knob 25mm	1
10	2115110	Drill Toggle Bottom Spring	1

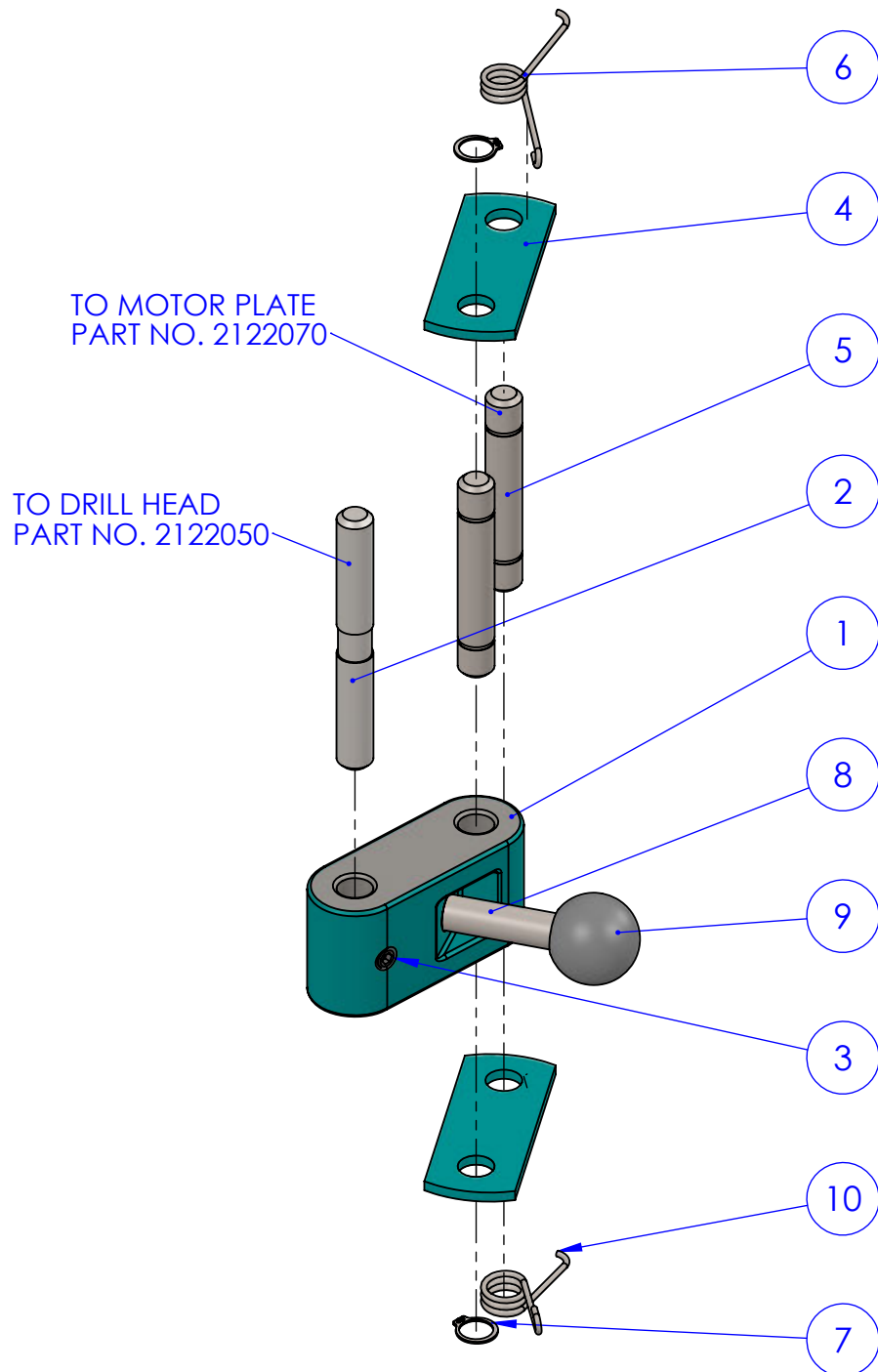

TO DRILL QUILL ASSEMBLY  
 PART NO. 2111300  
 Range 51-70mm  
 Suit 2M/3M Series

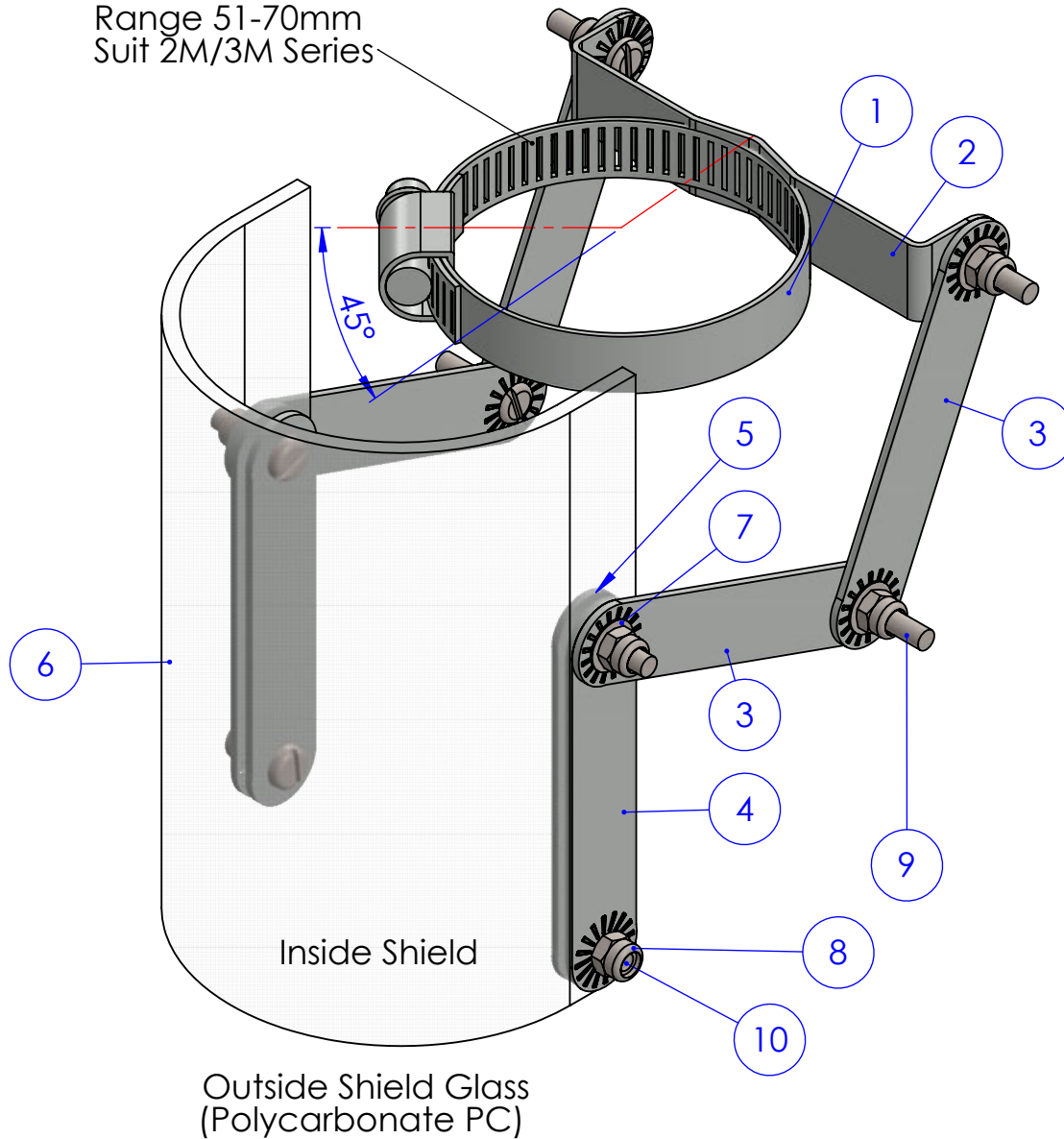

### CHUCK GUARD ASSEMBLY

ITEM NO.	PART NUMBER	DESCRIPTION	QTY.
1	1035870	Worm Gear Clamp, Range 51-70mm BandWidth 12mm	1
2	1033190	Link Arm U Shape	1
3	1033250	Link 2 (Both End Serated)	4
4	1033260	Link 3 (One End Serated)	2
5	1033270	Link 4 (Plain Ends)	2
6	1035850	Shield, Polycarbonate (PC)	1
7	8735480	Disc Spring $\phi 10 \times \phi 4.2 \times 0.4$	6
8	8725050	Nylon Lock Nut M4	8
9	8725040	Slotted Pan Head Screw M4x16	6
10	8725030	Slotted Pan Head Screw M4x10	2

**Note**  
 Nut & Disc Spring are outside the shield  
 Material: Mild Steel Zinc Plated for Item (1) (2) (3) (4) (5)



**BROBO GROUP**

Address : 8 Fowler Rd, Dandenong VIC 3175  
<https://brobo.com.au/>

ISSUED DATE 01.07.2019  
 DRAWN BY ANH

TITLE:

**2M/3M DRILL CHUCK  
 GUARD ASSEMBLY**

A4  
 SCALE:1:5  
 SHEET 1 OF 1

PART NO.  
**1031570**

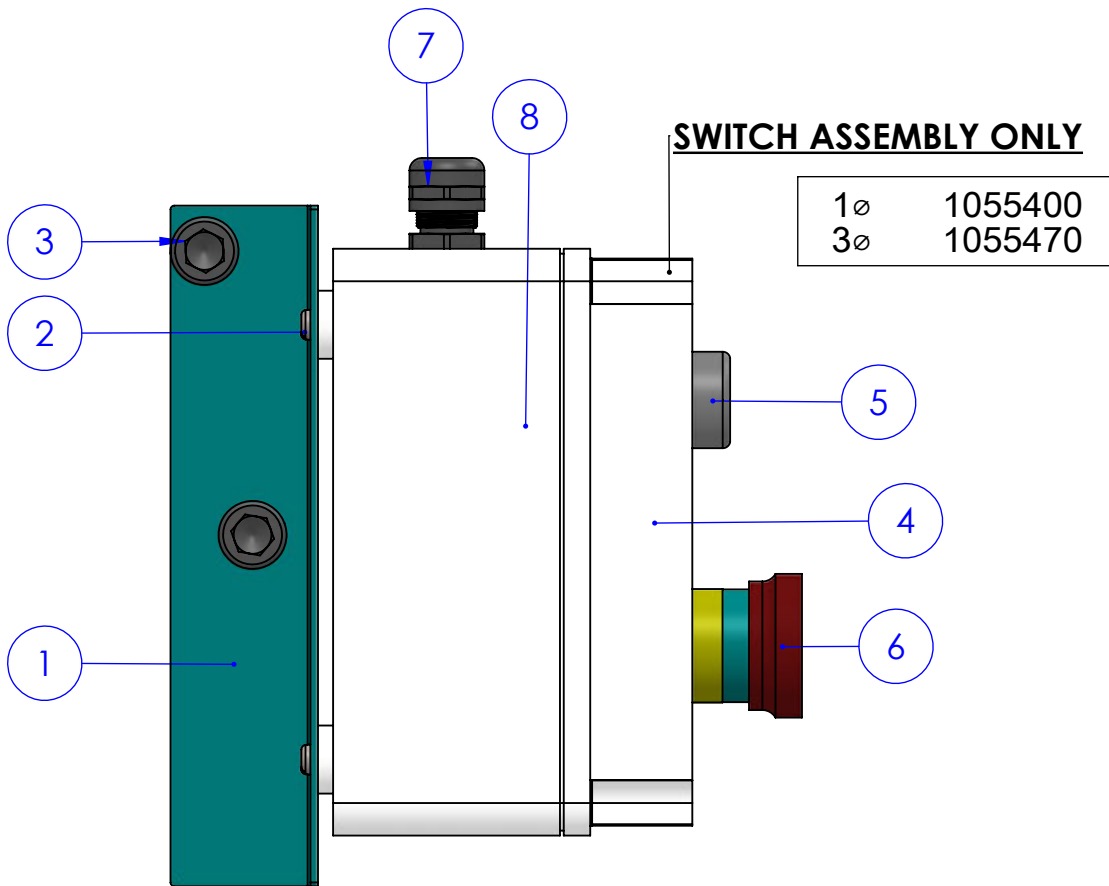

ITEM NO.	PART NO.	DESCRIPTION	QTY.
1	1033350	Switch Plate	1
2	8725040	Slotted Pan Head Screw M4x16	4
3	8705250	Socket Head Cap Screw M12x40	2
4	1055480	ENCLOSURE	1
5	TN2BF-1A	Start Button	1
6	Button Red	Emergency/Stop	1
7	1045750	Cable Gland M16	2
8	WARNING LABEL	Electrical Hazard Safety Sign	1

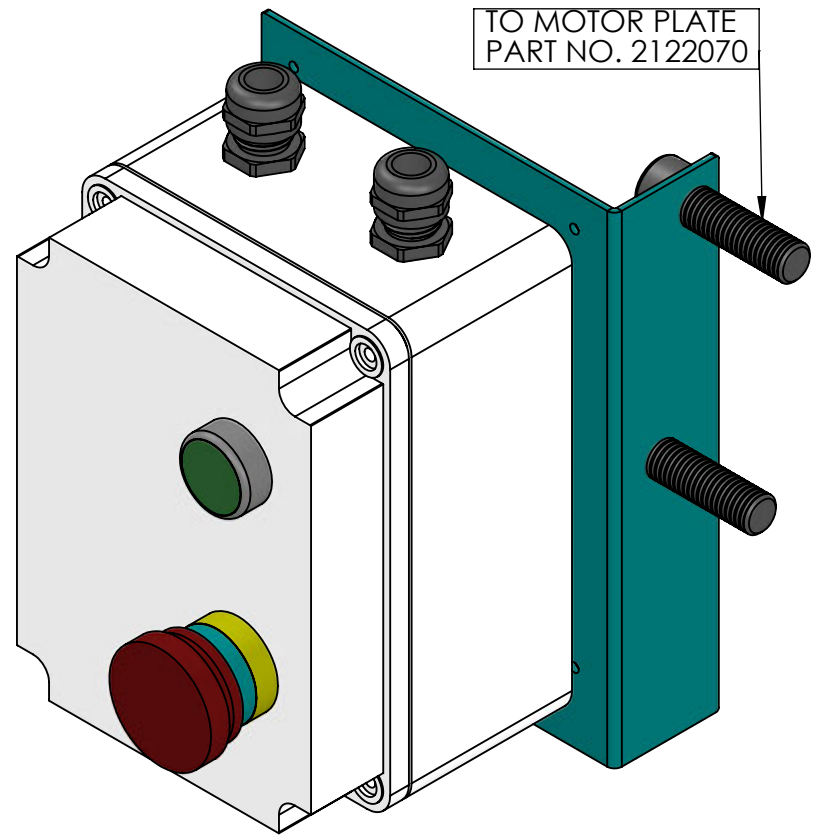

**3M SWITCH ASSEMBLY 3ø: 2131030**

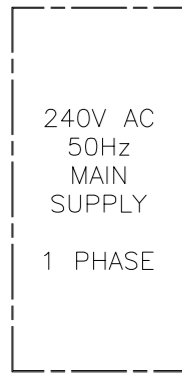

E  
L2 (N)  
L1 (A)

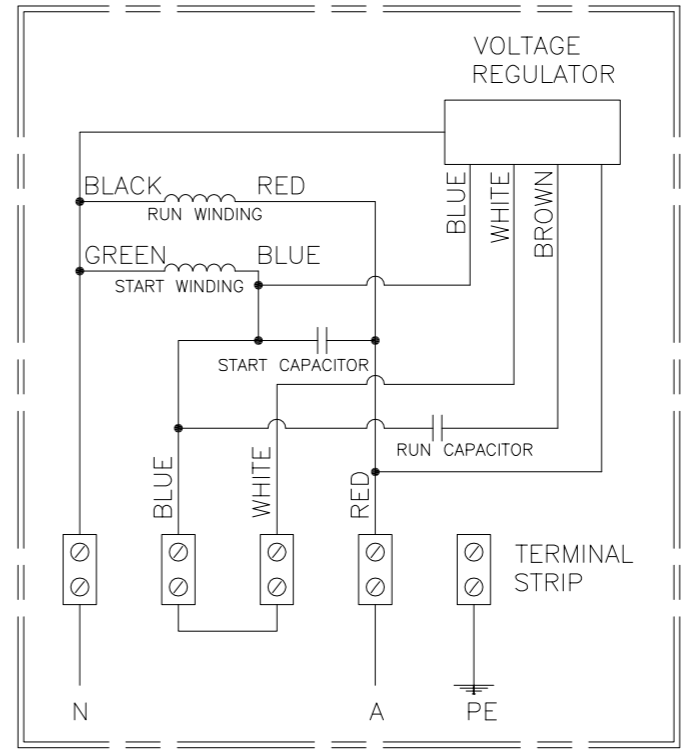
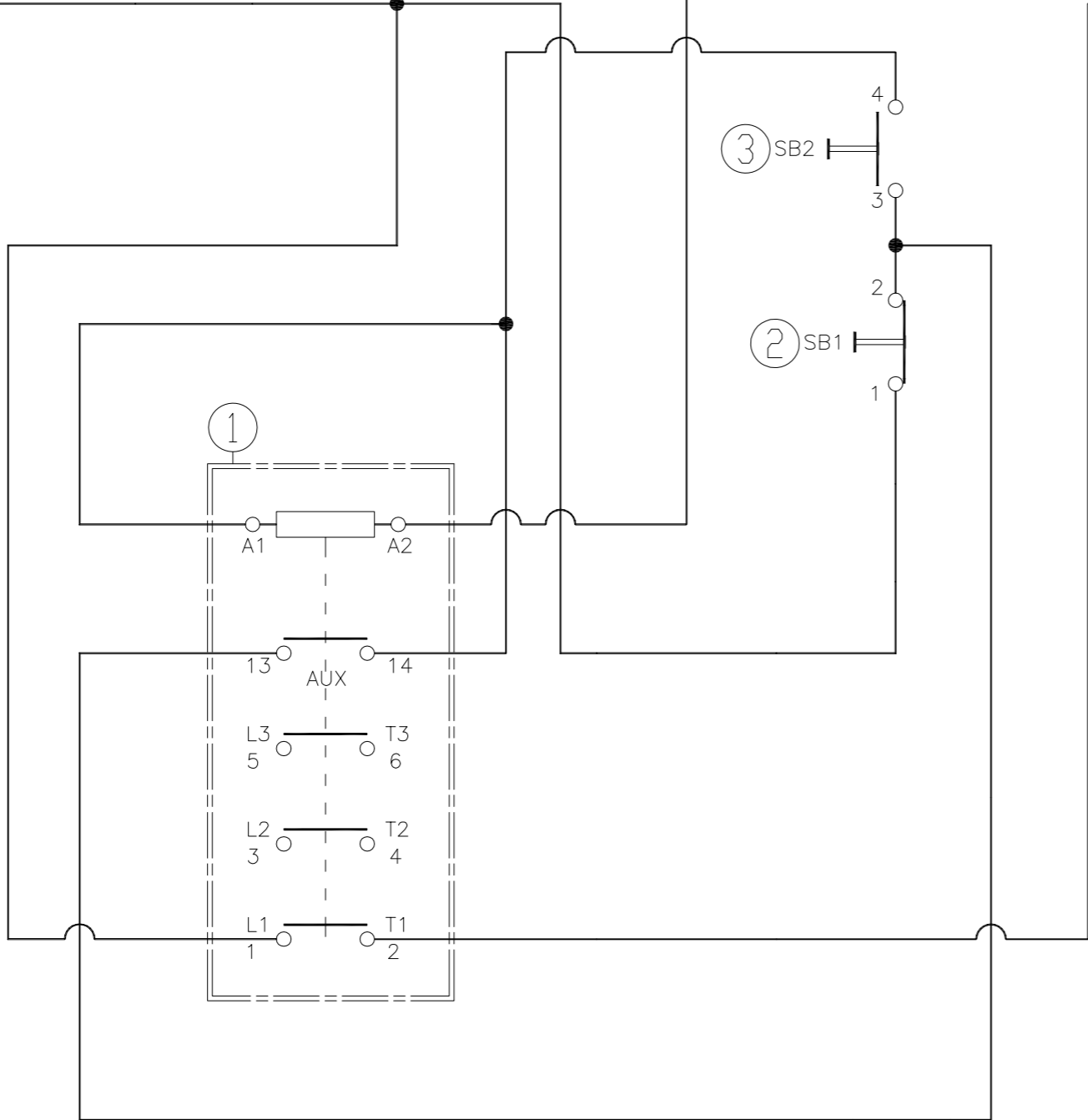

INTERNAL CIRCUIT  
FOR 1PH 3M DRILL MOTOR

ONE PHASE 3M DRILL MOTOR ELECTRICAL SCHEMATIC – STANDARD

NO.	DESCRIPTION
1. KM1	240V AC CONTACTOR
2. SB1	STOP/E-STOP PUSH BUTTON N.C
3. SB2	START PUSH BUTTON N.O
4. M1	0.75kW MOTOR 50HZ 240V AC 5.1A 1445 RPM

TECHNICAL INFORMATION
<u>CONTACTOR</u>
EATON DILEM-10 XTMC9A10
240V AC 50Hz IP20

AS COLOUR CODE 1PH

A	ACTIVE	BROWN
N	NEUTRAL	LIGHT BLUE
E	EARTH	GREEN/YELLOW

REV	DATE	DESCRIPTION	DRA.	SIGN
0	13.06.2018	ISSUED	ANH	

All rights reserved. Unless otherwise specified, no part of this publication may be reproduced or utilized otherwise in any form or by any means, electronic or mechanical, including photocopying, or posting on the Internet or an intranet, without prior written permission from Brobo Group

DRAWN	
CHECK	
APPROVE	
ENGINEER	ANH

PROJECT  
3M DRILL 1 PHASE – STANDARD

TITLE  
ELECTRICAL SCHEMATIC



BROBO GROUP  
Address : 8 Fowler Rd,  
Dandenong VIC 3175  
<http://brobo.com.au>

SCALE	NTS	REVISION	0
DWG NO.	E1802.3M.S01	SHEET	1 OF 1

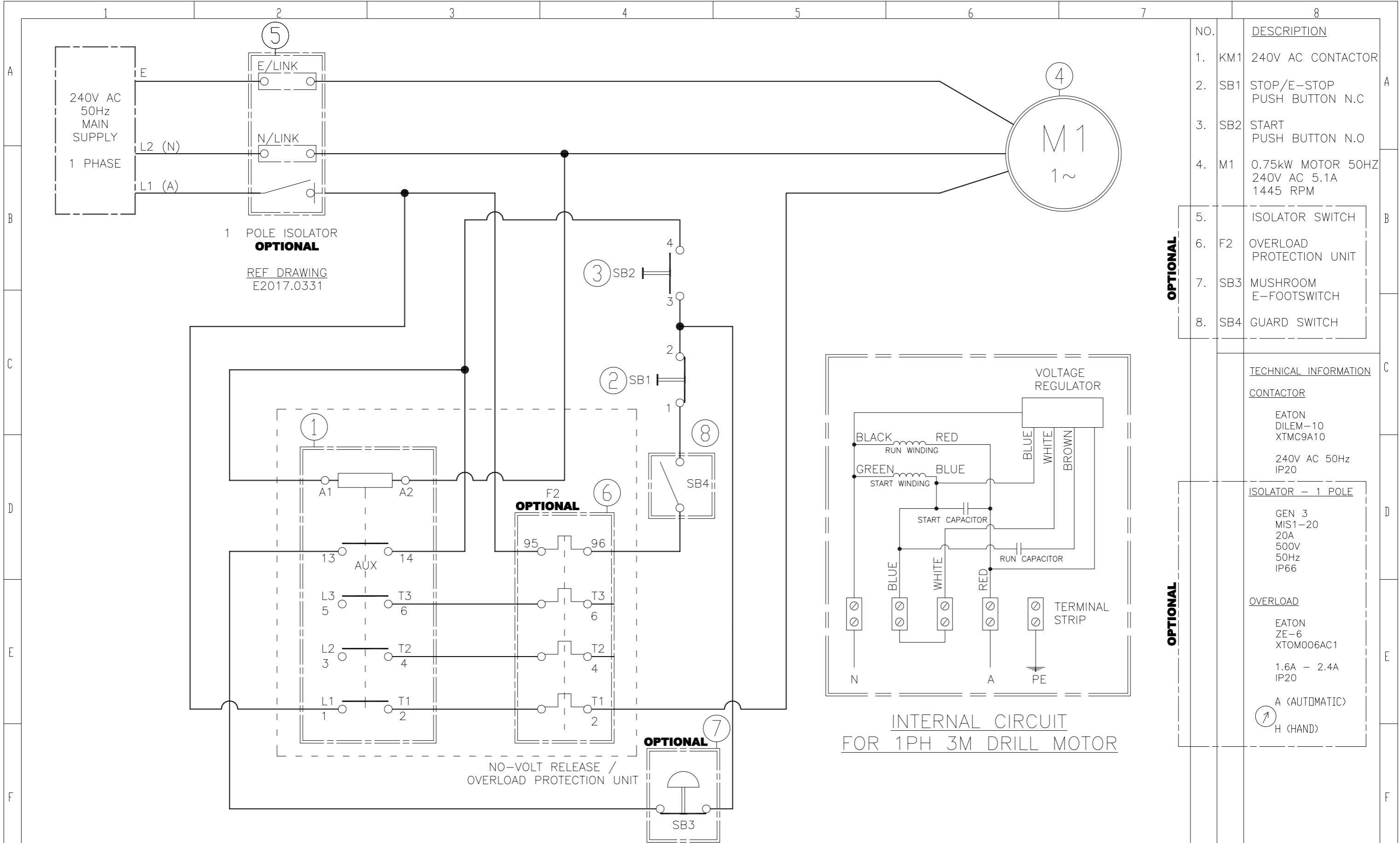

NO.	DESCRIPTION
1.	KM1 240V AC CONTACTOR
2.	SB1 STOP/E-STOP PUSH BUTTON N.C
3.	SB2 START PUSH BUTTON N.O
4.	M1 0.75kW MOTOR 50HZ 240V AC 5.1A 1445 RPM
5.	ISOLATOR SWITCH
6.	F2 OVERLOAD PROTECTION UNIT
7.	SB3 MUSHROOM E-FOOTSWITCH
8.	SB4 GUARD SWITCH

TECHNICAL INFORMATION	
<b>CONTACTOR</b>	
EATON DILEM-10 XTMC9A10	
240V AC 50Hz IP20	
<b>ISOLATOR - 1 POLE</b>	
GEN 3 MIS1-20 20A 500V 50Hz IP66	
<b>OVERLOAD</b>	
EATON ZE-6 XTOM006AC1	
1.6A - 2.4A IP20	
A (AUTOMATIC)	
H (HAND)	

ONE PHASE 3M DRILL MOTOR ELECTRICAL SCHEMATIC - (OPTIONAL SAFETY FEATURES)

AS COLOUR CODE 1PH				DRAWN		PROJECT	
A	ACTIVE	BROWN		CHECK		3M DRILL 1 PHASE - OPTIONAL	
N	NEUTRAL	LIGHT BLUE		APPROVE		TITLE	
E	EARTH	GREEN/YELLOW		ENGINEER	ANH	ELECTRICAL SCHEMATIC	
0	13.06.2018	ISSUED		DRA.	SIGN	SCALE NTS	
REV		DATE	DESCRIPTION			REVISION 0	
<small>All rights reserved. Unless otherwise specified, no part of this publication may be reproduced or utilized otherwise in any form or by any means, electronic or mechanical, including photocopying, or posting on the Internet or an intranet, without prior written permission from Brobo Group</small>							
DWG NO.		E1802.3M.S01.OPT		SHEET		1 OF 1	

**BROBO GROUP**  
 Address : 8 Fowler Rd,  
 Dandenong VIC 3175  
<http://brobo.com.au>

415V AC  
50Hz  
MAIN  
SUPPLY  
3 PHASE

E  
L3  
L2  
L1

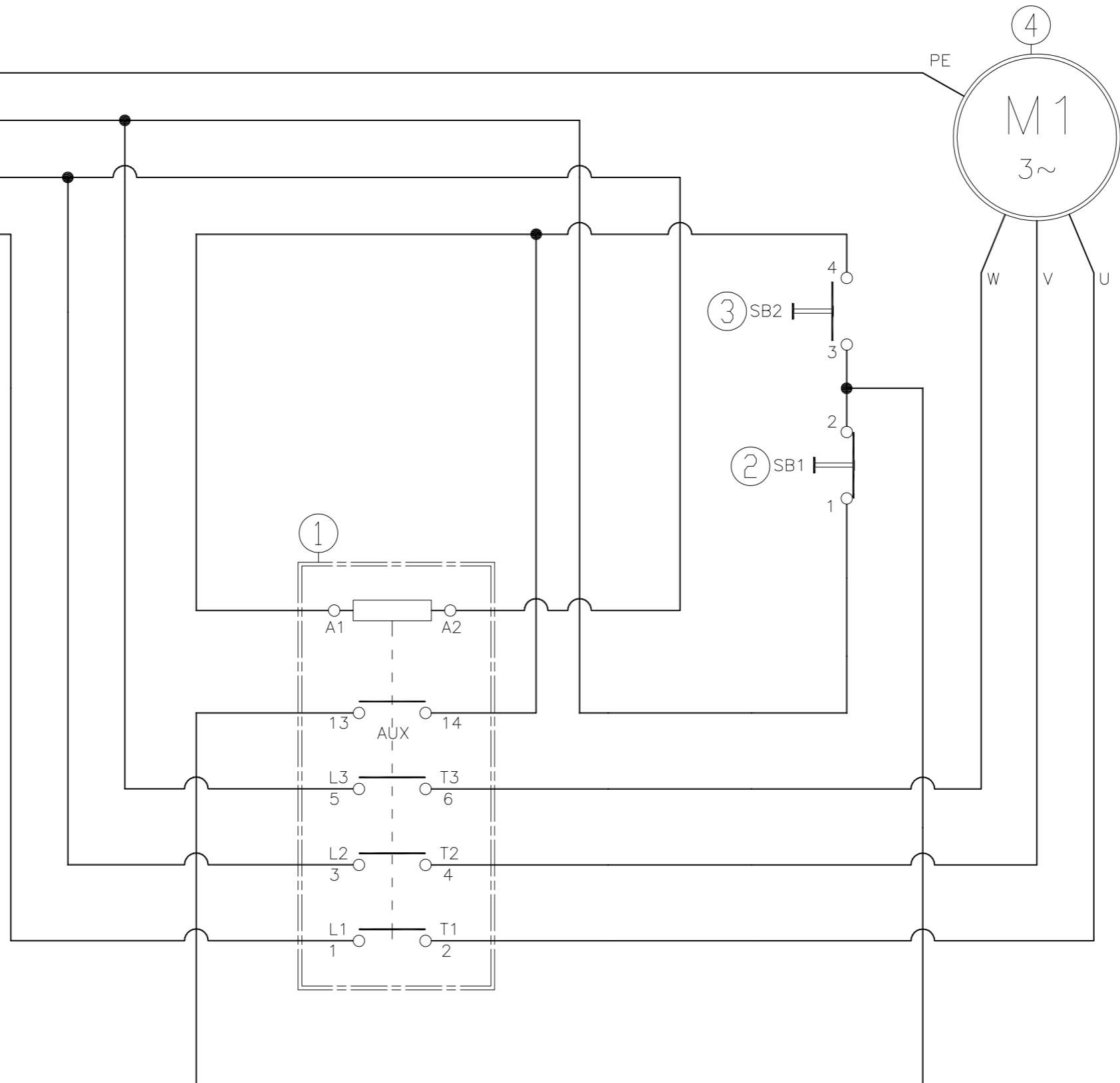

NO.	DESCRIPTION
1.	KM1 415V AC CONTACTOR
2.	SB1 STOP/E-STOP PUSH BUTTON N.C
3.	SB2 START PUSH BUTTON N.O
4.	M1 0.72KW MOTOR 50HZ 380-420V AC 2.3A

TECHNICAL INFORMATION  
CONTACTOR  
EATON  
DILEM-10  
XTMC9A10  
415V AC 50Hz  
IP20

3 PHASE 3M DRILL MOTOR ELECTRICAL SCHEMATIC – STANDARD

AS COLOUR CODE 3PH

L1	ACTIVE	BROWN
L2	ACTIVE	WHITE
L3	ACTIVE	DARK BLUE
E	EARTH	GREEN/YELLOW

0	13.06.2018	ISSUED	ANH	
REV	DATE	DESCRIPTION	DRA.	SIGN
All rights reserved. Unless otherwise specified, no part of this publication may be reproduced or utilized otherwise in any form or by any means, electronic or mechanical, including photocopying, or posting on the Internet or an intranet, without prior written permission from Brobo Group				

DRAWN	
CHECK	
APPROVE	
ENGINEER	ANH

PROJECT  
3M DRILL 3 PHASE – STANDARD  
TITLE  
ELECTRICAL SCHEMATIC

 BROBO GROUP  
Address : 8 Fowler Rd,  
Dandenong VIC 3175  
<http://brobo.com.au>

SCALE	NTS	REVISION	0
DWG NO.	E1802.3M.S03	SHEET	1 OF 1

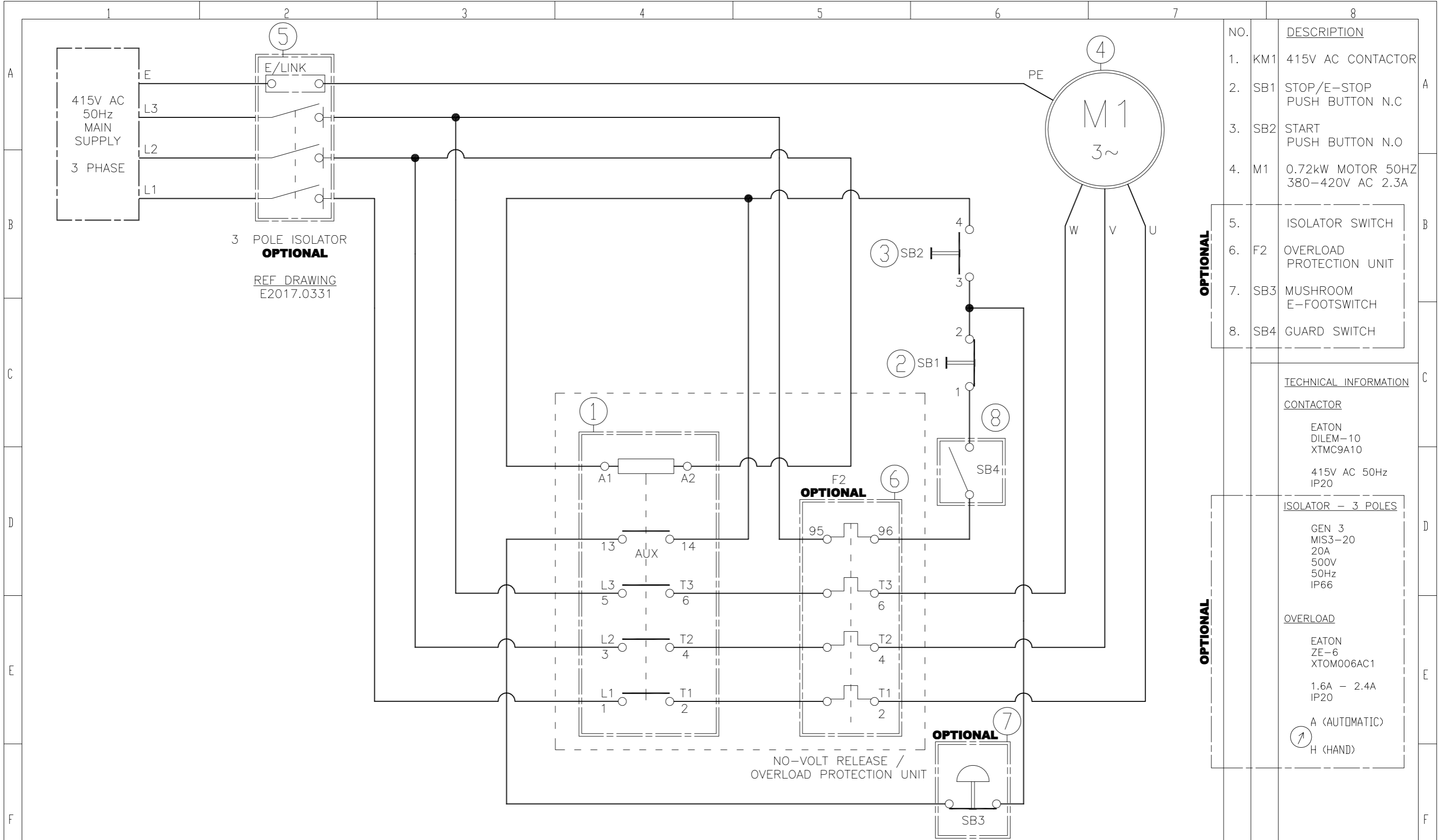

3 PHASE 3M DRILL MOTOR ELECTRICAL SCHEMATIC – (OPTIONAL SAFETY FEATURES)

NO.	DESCRIPTION
1.	KM1 415V AC CONTACTOR
2.	SB1 STOP/E-STOP PUSH BUTTON N.C
3.	SB2 START PUSH BUTTON N.O
4.	M1 0.72kW MOTOR 50HZ 380-420V AC 2.3A
5.	ISOLATOR SWITCH
6.	F2 OVERLOAD PROTECTION UNIT
7.	SB3 MUSHROOM E-FOOTSWITCH
8.	SB4 GUARD SWITCH

TECHNICAL INFORMATION	
<b>CONTACTOR</b>	
EATON DILEM-10 XTMC9A10  415V AC 50Hz IP20	
<b>ISOLATOR – 3 POLES</b>	
GEN 3 MIS3-20 20A 500V 50Hz IP66	
<b>OVERLOAD</b>	
EATON ZE-6 XTOM006AC1  1.6A – 2.4A IP20	
A (AUTOMATIC) H (HAND)	

AS COLOUR CODE 3PH	
L1	ACTIVE BROWN
L2	ACTIVE WHITE
L3	ACTIVE DARK BLUE
E	EARTH GREEN/YELLOW

REV	DATE	ISSUED	DESCRIPTION	DRA.	SIGN
0	13.06.2018	ISSUED		ANH	

All rights reserved. Unless otherwise specified, no part of this publication may be reproduced or utilized otherwise in any form or by any means, electronic or mechanical, including photocopying, or posting on the internet or an intranet, without prior written permission from Brobo Group

DRAWN		PROJECT	3M DRILL 3 PHASE – OPTIONAL
CHECK		TITLE	ELECTRICAL SCHEMATIC
APPROVE			
ENGINEER	ANH		

 BROBO GROUP  
Address : 8 Fowler Rd,  
Dandenong VIC 3175  
<http://brobo.com.au>

SCALE	NTS	REVISION	0
DWG NO.	E1802.3M.S03.OPT	SHEET	1 OF 1



**OPTIONAL**



**ISOLATOR: ONE PHASE**

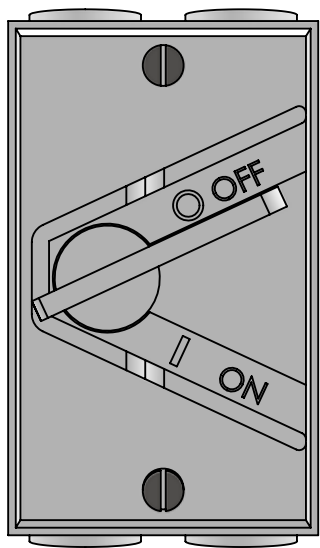

**ISOLATOR: FRONT**

**ONE PHASE**

SUPPLY  
10A/240V  
3PIN PLUG

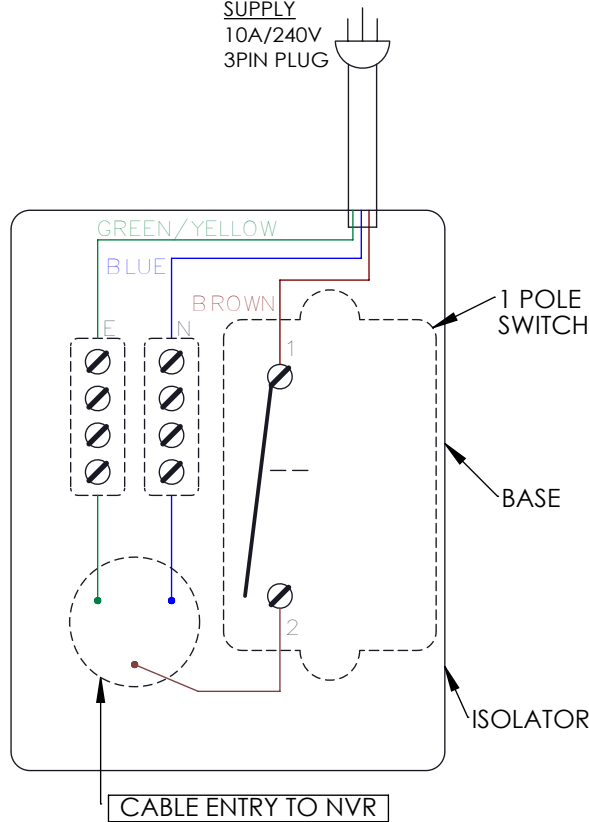

**THREE PHASE**

SUPPLY LINE

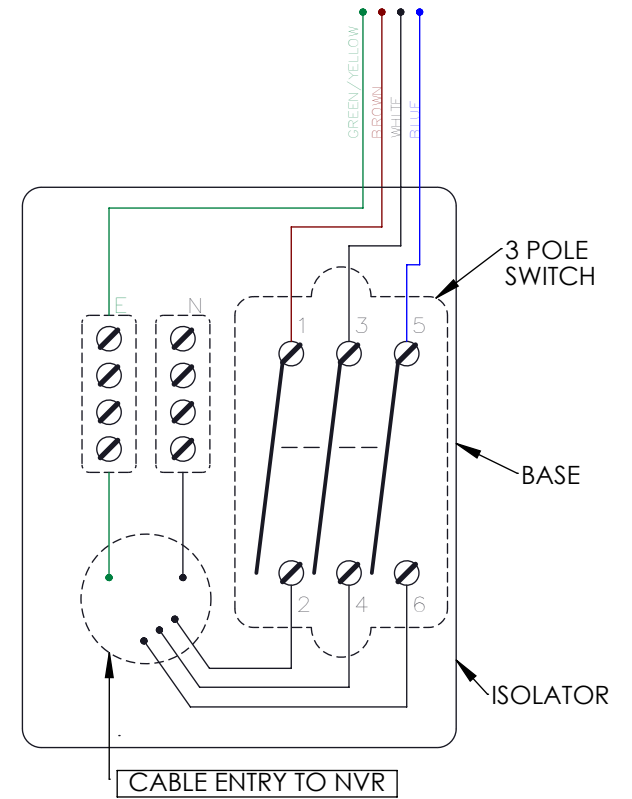

**COMPONENT / SCHEMATIC / WIRING DIAGRAMS FOR CONNECTION FOR 1 PHASE OR 3 PHASE CIRCUIT ISOLATOR**



ITEM NO.	PART NUMBER	DESCRIPTION	QTY.
1	1305040	Mushroom Footswitch Momentary	1
2	874573	Reducer M20/16	1
3	1041660	Mounting Plate	1
4	8745300	Straigh Adaptor Sp16/M16 B	2
5	8745290	SP 16 Conduit x 2.6 Meter	1
6	874510	Footswitch Lead 32/020 x 3 Meter	1

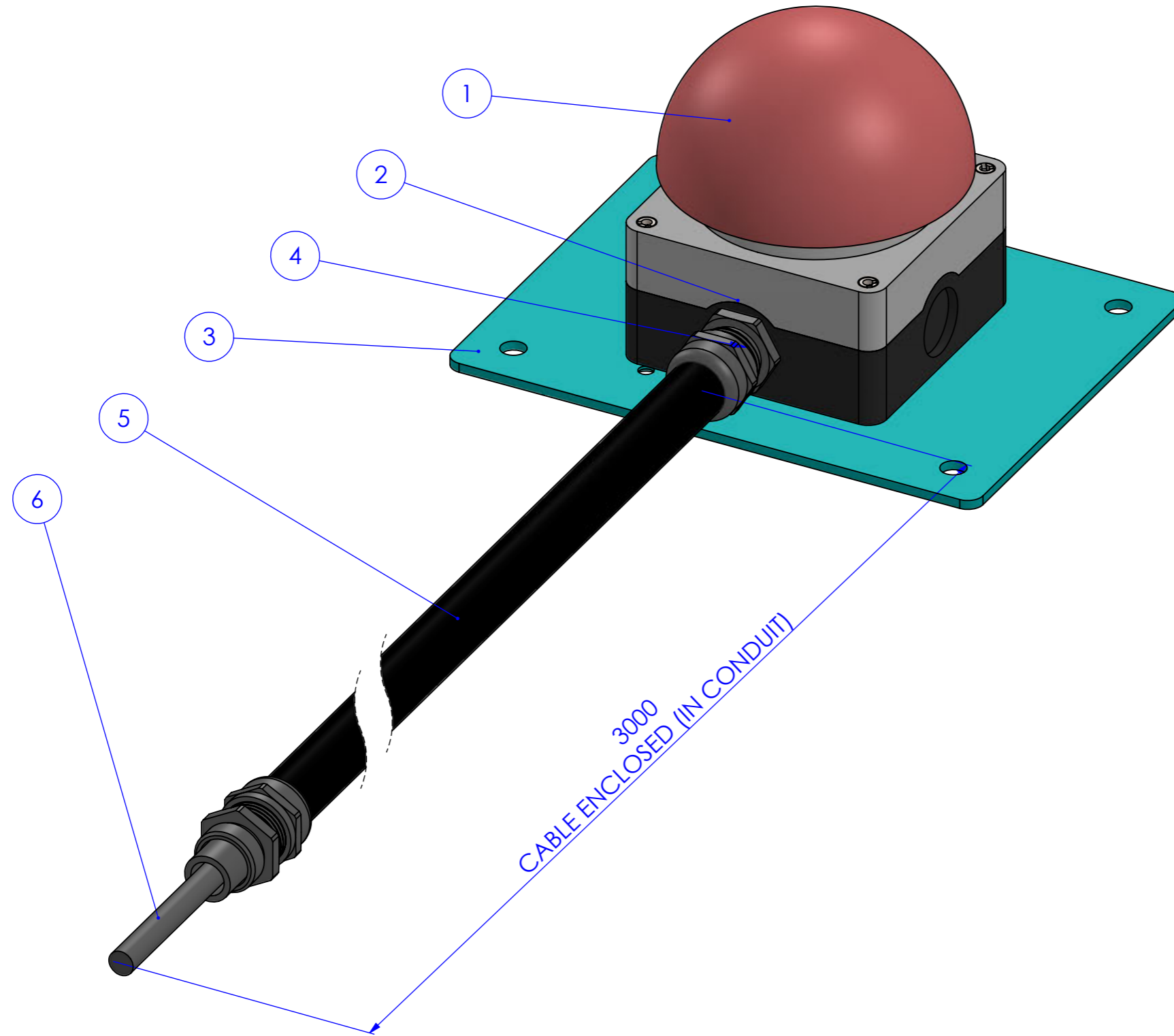

**OPTIONAL**

ALL RIGHTS RESERVED. THIS DRAWING MAY NOT BE REPRODUCED OR TRANSMITTED IN ANY FORM OR BY ANY MEANS IN PART OR IN WHOLE WITHOUT THE WRITTEN PERMISSION OF BROBO GROUP PTY LT

DRAWN ANH  
DATE 22.10.2019  
MATERIAL:  
WEIGHT:

UNLESS OTHERWISE SPECIFIED:  
DIMENSIONS ARE IN MILLIMETERS  
SURFACE FINISH:  
TOLERANCES:  
LINEAR:  
ANGULAR:

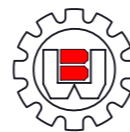

**BROBO GROUP**  
Address : 8 Fowler Rd, Dandenong VIC 3175  
<https://brobo.com.au/>

TITLE:

**FOOTSWITCH KIT  
ASSEMBLY**

DO NOT SCALE DRAWING SCALE:1:2

REVISION 0

DWG NO.

**1041650**

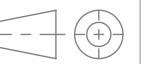

SHEET 1 OF 1 A3



## CHAPTER 5 – Maintenance & Selection of Consumables

---

### 5.1. Role of the Operator

The person operating & maintaining the **Brobo Group 3M Drill** must familiarise themselves with these instructions for their own safety & that of the others, in addition to safeguarding the production of the machine. Responsibility must be taken by the user on the general maintenance & up keeping of the unit as specified in this chapter, with particular emphasis on:

- Check to ensure that other operators of the machine always aware of & comply with the relevant safety instructions & standards as specified in *Chapter 2 - Safety & Accident Prevention*. Therefore, check that the safety devices are operational & work perfectly & personal safety requirements are complied with.
- Ensure that the working cycle is efficient & guarantees maximum productivity, inspect the:
  - Functions of the main components of the machine
  - The sharpness of the drill bit & lubricating fluid
  - Correct working parameters for the type of material being drilled
- Verify that the quality of each drilled hole meets the requirements & that the final product is free from any machining defects.

### 5.2. Maintenance Requirements

- All maintenance must be carried out with the power switched off & the machine in emergency stop condition.
- To guarantee for optimum operation, all spare parts must be **Brobo Group** originals.
- On completion of maintenance works, ensure that the replaced parts or any tools used have been removed from the machines before starting it up.
- Any behaviour not in accordance with the instructions for using the machine specified in this manual may create hazards and/or safety risks for the operator.
- Therefore, read & follow all the instructions for use & maintenance of the machine & those on the product itself.

### **5.3. General Maintenance of Functioning Components**

The general maintenance operations that should be carried out regularly are as follows:

- 1) Keep the rack lift table, overall machine, & path of the drilling free of any offcuts, accumulated swarf & lubricants by using compressed air or preferably thread-free cloth.
- 2) Lubricate the drill shaft & rotary chuck regularly with an *NLGI 2 extreme pressure grease, Shell Alvania No. 1 grease* or equivalent.
- 3) Check the belt condition & tension regularly. **Do not over tighten belts**, as this will inadvertently exert tension on the spindle & motor bearings. To provide the right tension, follow the belt manufacturer's recommendations & specifications.
- 4) Clean & lubricate any moving joints or sliding surfaces with good quality oil.
- 5) Clean the drill machine regularly & keep any unpainted surfaces lightly oiled to protect from rust & corrosion.
- 6) Ensure that the machine performs drill perpendicular to the work surface. If not, contact **Robo Group** engineering department.

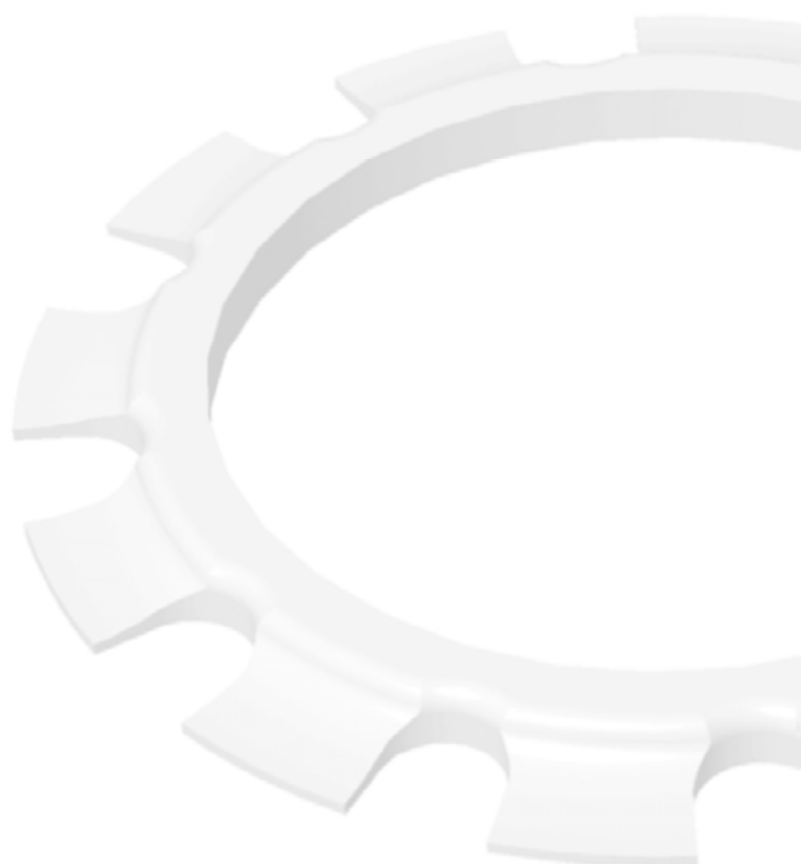



## CHAPTER 6 - Troubleshoot

### 6.1. General Troubleshooting

Below lists of some of the most common problems associated with the **Brobo Group 3M Drill** & the recommended troubleshooting procedures to undertake to rectify the situation. If the solutions provided do not resolve the problems, or the problem identified differs from those listed, immediately contact **Brobo Group** engineering department.

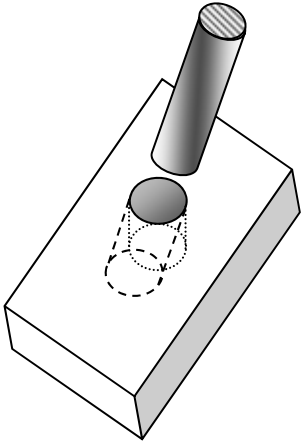
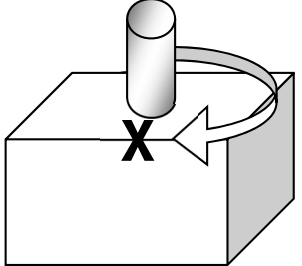
PROBLEM IDENTIFIED	DIAGNOSIS	SOLUTIONS
<i>Drilling is not at 90° or is angled to the rack lift table</i>	Workpiece not held firmly in vice clamp	Ensure that the vice clamps are securely fastened to the workpiece prior to drilling.
	Excessively fast feed rate forcing the drill bit through the material	Slow down the drill feed rate, else it might cause the drill bit to break & cause harm to the operator.
	The drill bit is not locked properly inside the chuck unit	Check that no swarf is lodged in the chuck unit. Remove aggregate using an air gun. Also, check that the chuck teeth are not worn. If so, the chuck unit might need to be replaced.
<i>Drill bit not turning penetrating the material</i>	Workpiece exceeds the recommended drilling capacity V-Belt slipping	Please ensure that the workpiece required drilling area does not exceed the recommended drilling capacity.
	Blunt drill bit	Check that the motor/pulley belts are not worn & if so, promptly replace them. The V-belts are available for purchase from <b>Brobo Group</b> .
	Excessive swarf trapped in the drill hole	Replace or sharpen the drill bit to continue with the drilling process. To reduce the amount of friction between the drill bit & parent material, apply a light coating or grease/lubricant onto the drill bit prior to drilling.

Worn bearings/seal in quill housing

Back off the feed rate on the drill. Use an air gun to clean out any remaining swarf in the hole. Reapply lubricant on the drill bit & continue with the drilling process.

The bearing & seal components can be purchased directly from your nearest **Brobo distributor**. For more information, please check [www.brobo.com.au](http://www.brobo.com.au)

*Worn/broken component*

Replace component

worn/broken

All component of the 3M drill is sold as spare parts (pending availability). Please contact your nearest **Brobo distributor** or our **Brobo Group** head office. Please visit [www.brobo.com.au](http://www.brobo.com.au) for more details.





**BROBO GROUP**®

A.C.N. 098 264 316  
A.B.N. 42 098 264 316

**BROBO GROUP (AUST) PTY. LTD.**

8 Fowler Rd, Dandenong, 3175  
Victoria, AUSTRALIA.

Tel: 61 3 9792 9944  
Fax: 61 3 9791 9955

Email: [info@brobo.com.au](mailto:info@brobo.com.au)  
Website: [www.brobo.com.au](http://www.brobo.com.au)

ISO 9001 Lic. 10292  
Standards Australia

Quality  
Endorsed  
Company



## APPENDIX - RISK/HAZARD ASSESSMENT

Hazard Type	Hazard Identification	Hazard Assessment	Hazard Management Strategies (Recommended for the Purchasing / Buyer / User)
Mechanical	Cutting/Severing	Low/Med	Keep machine correctly guarded & operational at all times. Keep hands clear of rotating the drill bit.
	Entanglement	Low	Do not wear loose jewellery, clothing or items that might get caught in the drill. Always keep the work area free of unnecessary objects or tools.
	Impact	Low	Wear protective safety glasses when utilising the drilling machine. Strongly encouraged that steel-capped safety boots be worn during operation of drill machine.
Electrical	Electrocution	Low	Remove the power supply when any maintenance and/or repairs are to be undertaken. The power source is to be isolated prior to opening electrical enclosures.
Noise	-	Low	Under no load testing, the noise level measured is below 80db (A). If the noise level becomes too high during a drilling cycle, stop the process & inspect for the problem, if any are present.
Substance	-	Low	Keep the work area clean & regularly remove excess coolant, oils, & another aggregate.
Hazardous Events	Unexpected Start-Up	Low	During a power failure, turn the machine off. If the problem persists, please contact <b>Brobo Group engineering</b> department.
Additional Hazards	Operator Error	Low	Ensure blades, clamps & materials are correctly secured.

MACHINE TYPE: \_\_\_\_\_

SERIAL NO.: \_\_\_\_\_

RECEIVING COMPANY: \_\_\_\_\_ (SAFETY OFFICER)

## **Brobo Group Warranty**

- 1.1 *The supplier warrants that all goods supplied by it shall be free from defects in materials & workmanship for a period of twenty-four (24) months from the date of delivery to the Customer. ("The Warranty Period"), on the following terms & conditions.*
- 1.2 *The Customer shall promptly provide written particulars to the supplier on becoming aware of any defect in the goods during the Warranty Period, & shall provide the Supplier with all necessary access, facilities & information to enable the Supplier to ascertain or verify the nature & the cause of the defect & to carry out its obligations under this warranty.*
- 1.3 *The Supplier's obligation under this warranty is limited to repairs of the defect goods & the Supplier is under no obligation to replace the goods or refund the value of the goods to the Customer.*
- 1.4 *If the goods are, in the opinion of the Supplier, not defective or if any defect is attributable to any one or more of the following circumstances then the Supplier is under no obligation whatsoever to the Customer:*
  - 1.4.1 *The use of the goods for a purpose other than that for which they were intended to be used;*
  - 1.4.2 *The repair, modification or alteration of the goods by any person other than the Supplier;*
  - 1.4.3 *Where the defect has arisen due to misuse, neglect or accident, howsoever arising;*
  - 1.4.4 *Where the defect has arisen due to the installation of the goods which were, in the reasonable opinion of the Supplier, incorrectly carried out*
  - 1.4.5 *Where the goods have not been correctly stored or maintained*
  - 1.4.6 *Where the defect has arisen due to normal wear & tear on the goods*
- 1.5 *The Supplier is under no obligation under this warranty where the Customer has failed to observe the terms of payment for the goods or any other obligation imposed by the terms & conditions of this warranty.*
- 1.6 *In the event that the Supplier is supplying goods, which have been manufactured by third parties, the Customer shall be entitled to the benefit of any Manufacturer's Warranty in respect of such goods. The Customer acknowledges that the Supplier accepts no responsibility whatsoever for any Manufacturer's Warranty or any claim howsoever arising from the use of the goods, whether singularly or in combination with other products.*
- 1.7 *The Supplier shall not be liable for any indirect or consequential losses or expenses suffered by the Customer, howsoever caused.*
- 1.8 *Except as specifically set out herein, or in writing by way of catalogue or pamphlet or otherwise provided by the Supplier to the Customer any term, representation, condition or warranty in respect of the quality, condition or description of the goods, whether implied by statute, common law, trade usage, custom or otherwise, is hereby expressly excluded.*

*This warranty is given by **Brobo Group Pty Ltd**, ABN: 42 098 264 316*

*Address: 8 Fowler Rd, Dandenong South, VIC 3175*



*03 9794 8751*



*03 9794 8792*



*[info@brobo.com.au](mailto:info@brobo.com.au)*

*This warranty is provided in addition to other rights & remedies you have under the law: Our goods come with guarantees which cannot be excluded under the Australian Consumer Law. You are entitled to replacement or refund for a major failure & to compensation for other reasonably foreseeable loss or damage. You are also entitled to have the goods repaired or replaced if the goods fail to be of acceptable quality & the failure does not amount to a major failure.*