

# **HERCUS**

## **260 LATHE**

### **MAINTENANCE MANUAL**

**F.W. HERCUS**

12 CAMIRA STREET  
REGENCY PARK, S. AUST. 5010  
PH:8346 5522 FAX:8346 5811

## HERCUS260TLATHE

This Manual is intended to give guidelines for the regular maintenance of the Lathe, together with details of recommended procedures for the replacement of parts. In particular, the Manual is directed towards the technical educational environment where the machine is subjected to continual use by different operators who are not always familiar with normal machine-care procedures.

### Contents

1/	Good operating procedures	Page 2
2/	Lubrication	Page 3
3/	Checks and adjustments	Page 4
4/	Replacement of Parts —	
	(a) Cross Feed Nut	
	(b) Compound Rest Nut	
	(c) Cross Feed or Compound Rest Screw — including procedure for Elimination of wear on existing parts	
	(d) Headstock Spindle	Page 6
	(e) Back Gear	
	(f) Drive Belt from yoke	
5/	Appendix A	
	Assembly Drawings	
	Appendix B	
	Maintenance Tool Drawings	
	Appendix C	
	List of other material on 260 Lathe	

## GOOD OPERATING PROCEDURES

- 1/ Do not rest tools on the bed or slideways
  
- 2/ Keep the bed and slides clean and free from swarf and moisture
  
- 3/ Always clean the spindle nose and mating component before mounting
  
- 4/ Do NOT leave the key in the lathe chuck
  
- 5/ When removing chucks from the spindle, engage the back gear to lock the spindle.  
If the chuck is tight, use a bar between the jaws with an even pressure to loosen.
  
- 6/ Do NOT engage gears whilst the machine is running.

## LUBRICATION

The oiling points are illustrated on the photograph from the "Text Book of Turning" reproduced below. When in regular use, all points should be oiled daily with a few drops and the excess wiped off.

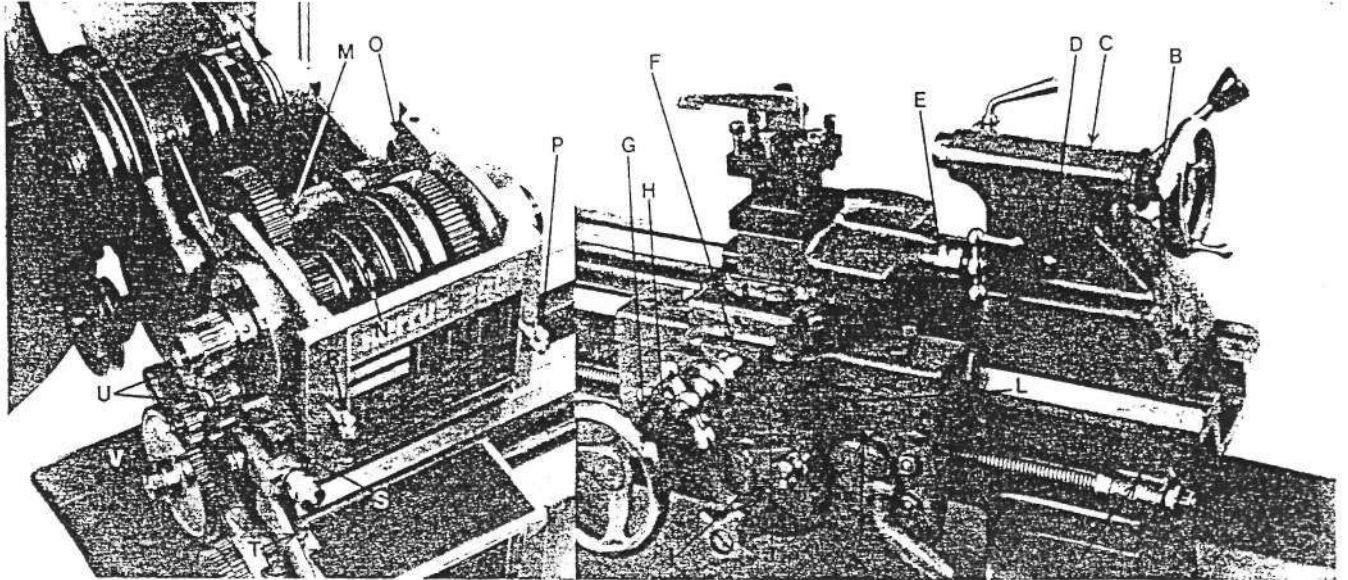

<p>A - Rear Leadscrew Bearing</p> <p>B - Tailstock Handwheel Bearing</p> <p>C - Tailstock Screw</p> <p>D - Tailstock Clamp (at back of Tailstock)</p> <p>E - Compound Rest Screw Bearing</p> <p>F - Cross Feed Screw Bearing</p> <p>G - Apron Handwheel Bearings</p> <p>H - Rack Pinion Bearing</p> <p>I - Worm Drive</p> <p>J - Cross Feed Pinion Bearings</p> <p>K - Half Nut Cam</p>	<p>L - Half Nuts</p> <p>M - Back Gear*</p> <p>N - Cone Pulley*</p> <p>O - Front Back Gear Spindle Bearings</p> <p>P - Front Main Spindle Bearing!</p> <p>Q - Rear Back Gear Spindle Bearing</p> <p>R - Rear Main Spindle Bearing</p> <p>S - Reverse Shaft Bearing</p> <p>T - Gearbox</p> <p>U - Twin Reverse Gears (2)</p> <p>V - Idler Gear Bearings</p> <p style="text-align: center;">*Remove screw to oil tFill until oil remains in bottom of elbow</p>
---	--

Oil should also be applied at the same interval to the bed ways, the cross slide and compound rest dovetails, the tailstock barrel, the leadscrew threads and the back gear and change gear teeth. Every 5 or 6 days, oil should also be applied to the countershaft yoke pivot points and the belt tensioning eccentric shaft.

Recommended lubricants are listed below: —

Supplier	Recommended Oil
<p>MOBIL OIL AUST.                      CALTEX OIL (AUST.) PTY. LTD.                      SHELL CO. OF AUST.                      AMPOL PETROLEUM LTD.                      CASTROL LTD.                      H. C. SLEIGH LTD.                      B.P. AUST. LTD.                      NEPTUNE OIL CO.</p>	<p>Mobil Vactra Oil Heavy                      Regal Oil P.C. (R. &amp; O)                      Vitrea Oil 33                      Gernol Oil 37                      Perfecto R.R.                      Purol Heavy Medium                      B.P. Energol H.P. 30                      P. 13</p>

## CHECKS AND ADJUSTMENTS

The following adjustments should be checked periodically to ensure trouble free operations:—

### 1/ **Belt Tension**

The motor and drive belts should be checked regularly for correct tensioning. The belt tension is correctly set when a light finger pressure midway between the pulleys will give a deflection of 10 -13 mm. The drive belt tension is adjusted by the knob at the rear of the drive unit. The motor belt tension is adjusted by slackening the motor base strap and re-clamping in the correct position.

### 2/ **Back Gear Tensioning Screw**

This screw is located in the front arm of the headstock above the back gear eccentric. It should be set so that there is sufficient resistance to the movement of the back gear lever to prevent its moving out of mesh when in use. **A 5/32 A/F hexagon key is required for this operation.**

### 3/ **Rear Saddle Keep Plate**

Two hexagon head screws with spring washers attach this keep plate to the rear of the saddle. **The correct setting for this keep plate is obtained by tightening both screws and then backing each off by half a turn.**

### 4/ **Front Saddle Lock Screw**

This should be **finger tight for normal use** and only tightened when the saddle is to be locked.

### 5/ **Tailstock Clamp Bolt**

This should be set to give a clamping position with the handle at about 60° from the horizontal. To adjust, remove the tailstock from the bed and reset the position of the bolt in the clamp nut.

### 6/ **Cross Slide and Compound Rest Gibs**

The gibs are adjusted using the gib spanner {Drawing M6 — Appendix B) and screw driver. With the screw driver in the gib screw, slacken the lock nut, adjust the gib screw and re-tighten each locknut in turn. When properly set, the slide should move smoothly with no slack.

### 7/ **Fastening Screws**

To prevent problems arising from screws and components working loose, regular tightening of the following screws should be made every 3 months:—

- |                                     |   |                            |
|-------------------------------------|---|----------------------------|
| a/ Motor Pulley Screw               | — | using 5/32 A/F Hexagon Key |
| b/ Countershaft Drive Pulley Screw  | — | using 5/32 A/F Hexagon Key |
| c/ Countershaft Cone Pulley Screw   | — | using 5/32 A/F Hexagon Key |
| d/ Gearbox Retaining Screws         | — | using 7/32 A/F Hexagon Key |
| e/ Leadscrew Bearing Bracket Screws | — | using 7/32 A/F Hexagon Key |
| f/ Rack Retaining Screws            | — | using 3/32 A/F Hexagon Key |
| g/ Saddle to Apron Screws           | — | using 5/16 A/F Hexagon Key |

## REPLACEMENT OF PARTS

### 1/ Cross Feed Nut

Wind the cross slide forward until the nut comes off the screw

Loosen the locking screw and remove the nut

Transfer the locking pin and screw to the new nut

Insert the new nut in the cross slide

Engage the screw in the nut and wind the cross slide forward as far as possible

**Back off one turn and tighten the locking screw.**

### 2/ Compound Rest Nut

Wind the slide back as far as possible. Use a "C" spanner to remove the compound rest screw assembly.

Loosen the nut locking screw and remove the nut

Insert the new nut

Replace the compound rest screw assembly

Wind the slide fully forward

**Back off one turn and tighten the locking screw**

### 3/ Cross Feed or Compound Rest Screw

(The same procedure can be used to eliminate wear on an existing screw)

The Screw Assembly is removed as one unit, using a "C" spanner (Drawing M6 - Appendix B) and then taken apart. If new parts are being fitted, then they are substituted for the worn parts.

When re-assembling a shim washer "A" of app. 0.03mm (0.0012") is placed between the graduated collar and the face of the bushing. The screw is pushed hard into the bushing, the graduated collar pushed hard against the shim washer and secured with the lock screw "B". The shank of the screw is then gripped in a 3 jaw chuck in a lathe and a light cut taken across the face of "C". The shim is then removed and the unit re-assembled and replaced.

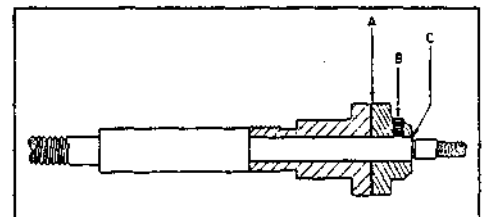

When another lathe is not available to carry out this operation on the Cross Feed Screw, clamp the cross slide by tightening one gib screw and use the compound rest set at 90° to take the facing cut. When operating on the Compound Rest Screw, clamp that slide by tightening one gib screw.

**4/ Procedure for removing and replacing Headstock Spindle for replacing any part requiring this operation**

This is the preferred procedure using the spindle puller details of which are given on Drawings M4 and M5 in Appendix "B".

An alternative method is given in the Text Book of Turning.

The front and rear bearing caps are removed and the take-up nut unscrewed using the "C" spanner illustrated on Drawing M6.

To remove the spindle, place the puller in position as shown in Drawing M1 and tighten the puller nut (2) to pull the spindle clear of the rear bearing cone and bull gear. The puller nut is then removed and the spindle completely withdrawn.

To replace the spindle, insert it through the bull gear and cone pulley, lining up the bull gear keyway. Position the puller as shown in Drawing M2 and tighten the puller nut (2) to pull the spindle through the bull gear. The nut and spacer are then removed and the spacing collar placed on the spindle and turned until the keyway spring engages in the keyway.

The rear bearing is then pulled on as shown in Drawing M3.

Finally, the front and rear bearing caps are replaced and the takenut screwed on and tightened to give the recommended preload of 0.2 Newton metres and the lock screw tightened.

**5/ Procedure for removing and replacing the Back Gear Shaft for replacing any part requiring this operation. Refer Drawing A1 - Appendix A**

Slacken off the back gear tension screw (138) and remove the back gear lever adjusting screw (141). (It is advisable to loosen the nut (142) just sufficiently to free the screw and then take the two off as one unit to give a guide to the correct positioning when re-assembling). Drive out spring pin (135) and remove the back gear lever (136) together with the back gear shaft (133).

To re-assemble, insert the back gear lever and shaft, and replace the spring pin. The adjusting screw and nut are then replaced and locked in position to give the correct gear backlash and the tension screw re-set.

**6/ Procedure for fitting a belt over the countershaft. Drawing A36 - Appendix A**

(Early model machines had a one piece yoke and the procedure in this case is outlined in the Text Book of Turning)

Firstly remove the Drive Pulley (216), loosen the locking screw (226) and tap the pivot shaft (225) out towards the tailstock until it clears the left-hand yoke section. Remove the clamping screw (204) and swing the left-hand yoke section (209) forward until it is above the countershaft (211). The belt may then be fitted over the cone pulley (212)

Re-assemble by swinging the yoke section back into position, replacing the clamping screw, tapping the pivot shaft back into position, locking it with the screw and replacing the driving pulley.

**APPENDIX "A"      Assembly Drawings**

A 1                      T Headstock

A 5                      Reverse Bracket

A 6                      Tailstock

A 9                      AM Gearbox

A 12, A 18, A 23      AM Apron, Saddle and Compound Rest

A 14                     CM Apron

A 36                     T Drive Unit



A1	T. Headstock	April 1980
	HERCUS 260 Lathe	
	F.W. Hercus Pty. Ltd.	

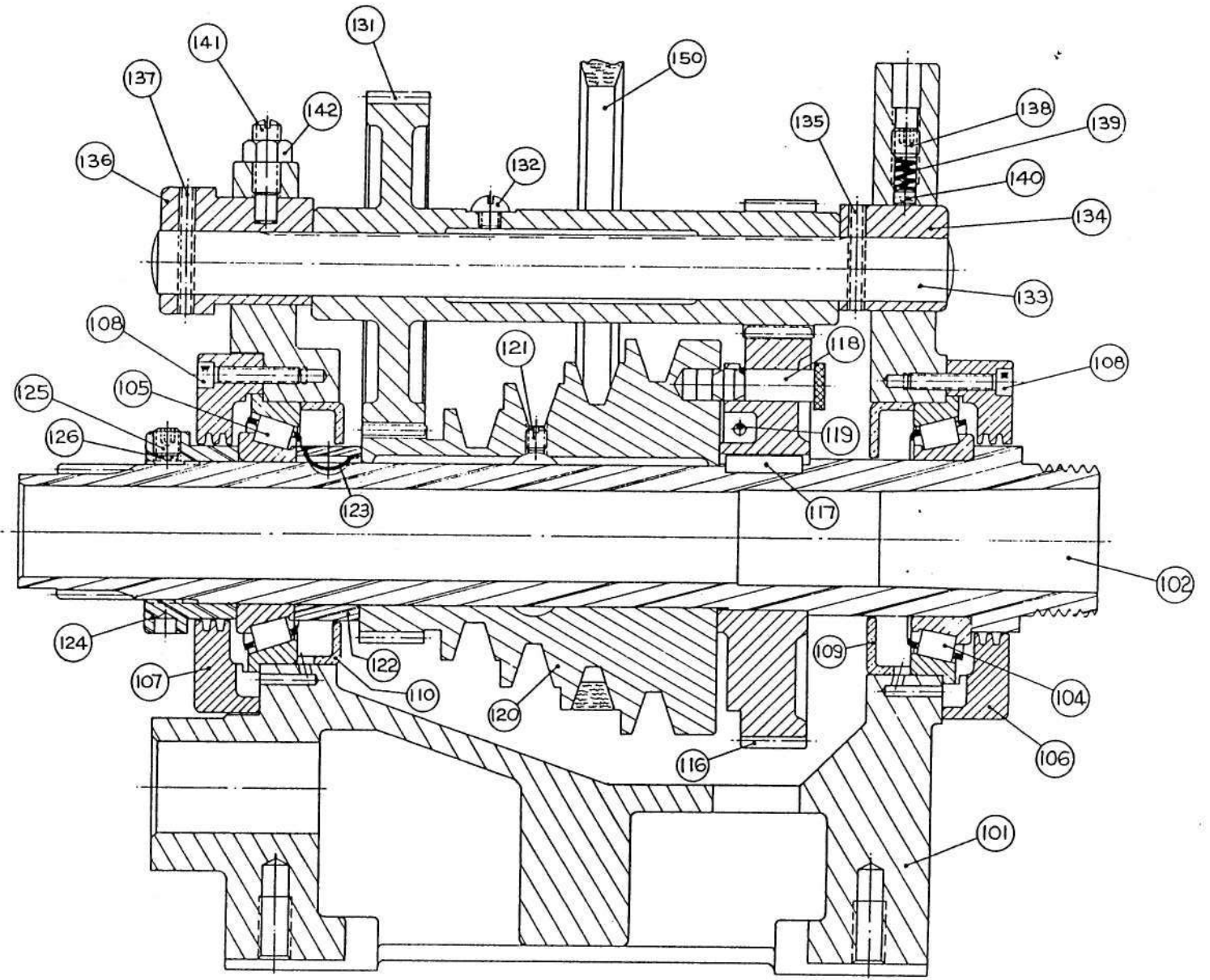

	Reverse Bracket	April 1980
A5	HERCUS 260 Lathe	
	F.W. Hercus Pty. Ltd.	

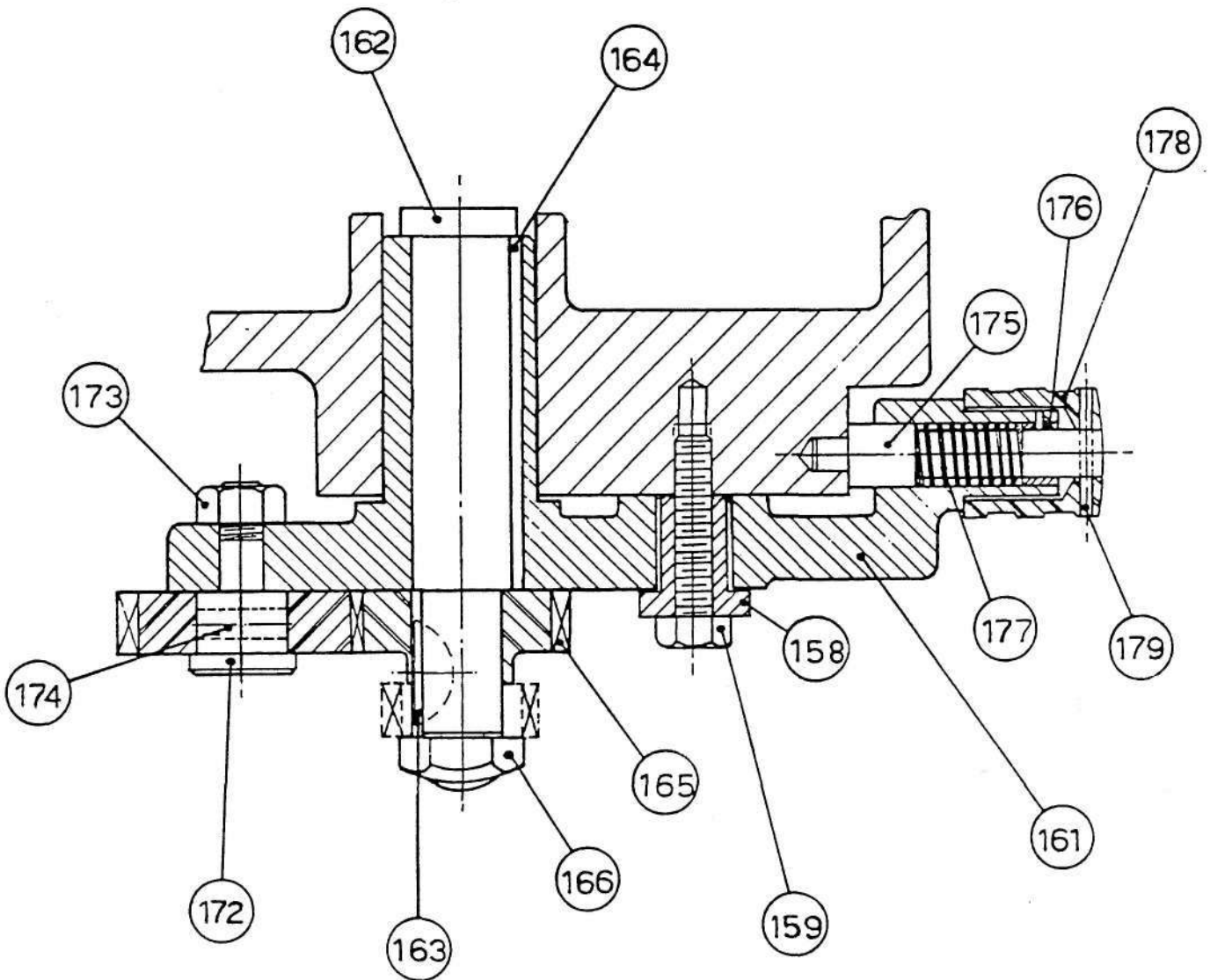
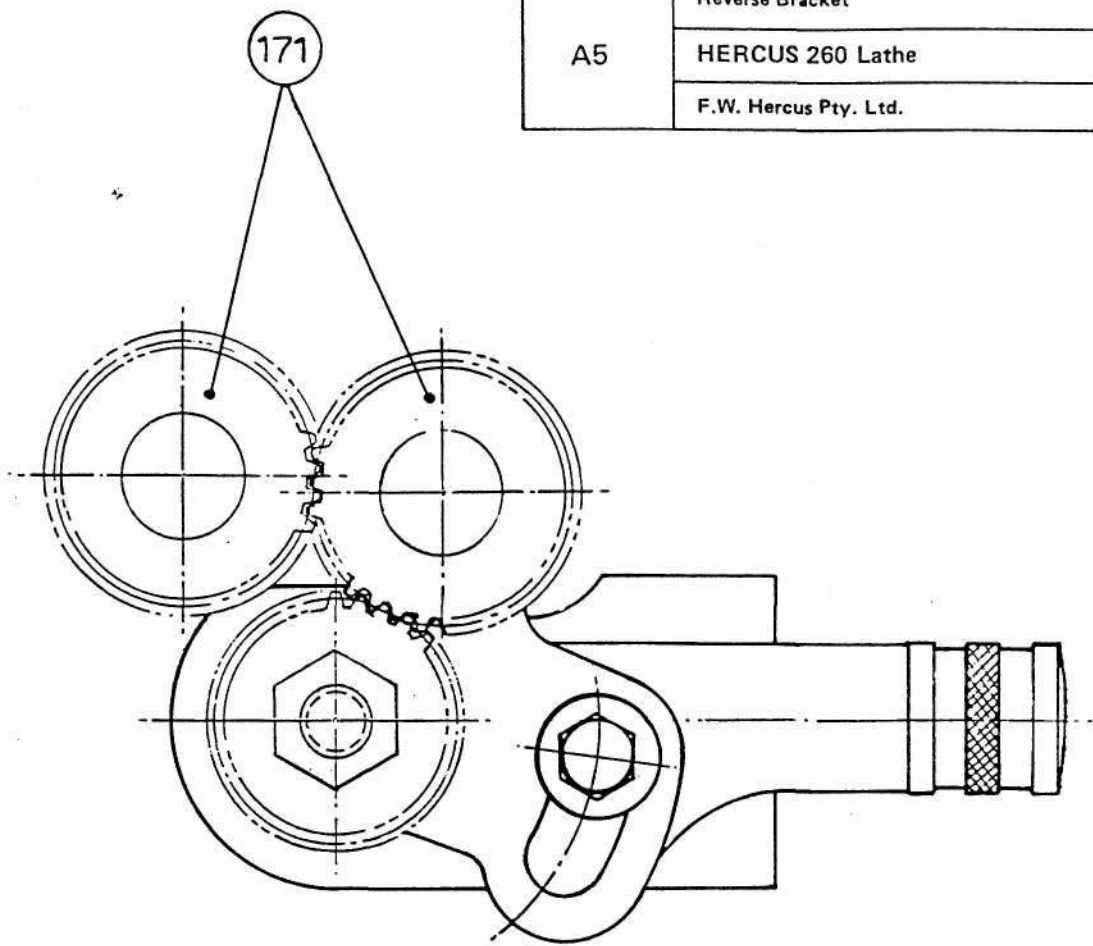

A6	M. Tailstock	April 1980
	HERCUS 260 Lathe	
	F.W. Hercus Pty. Ltd	

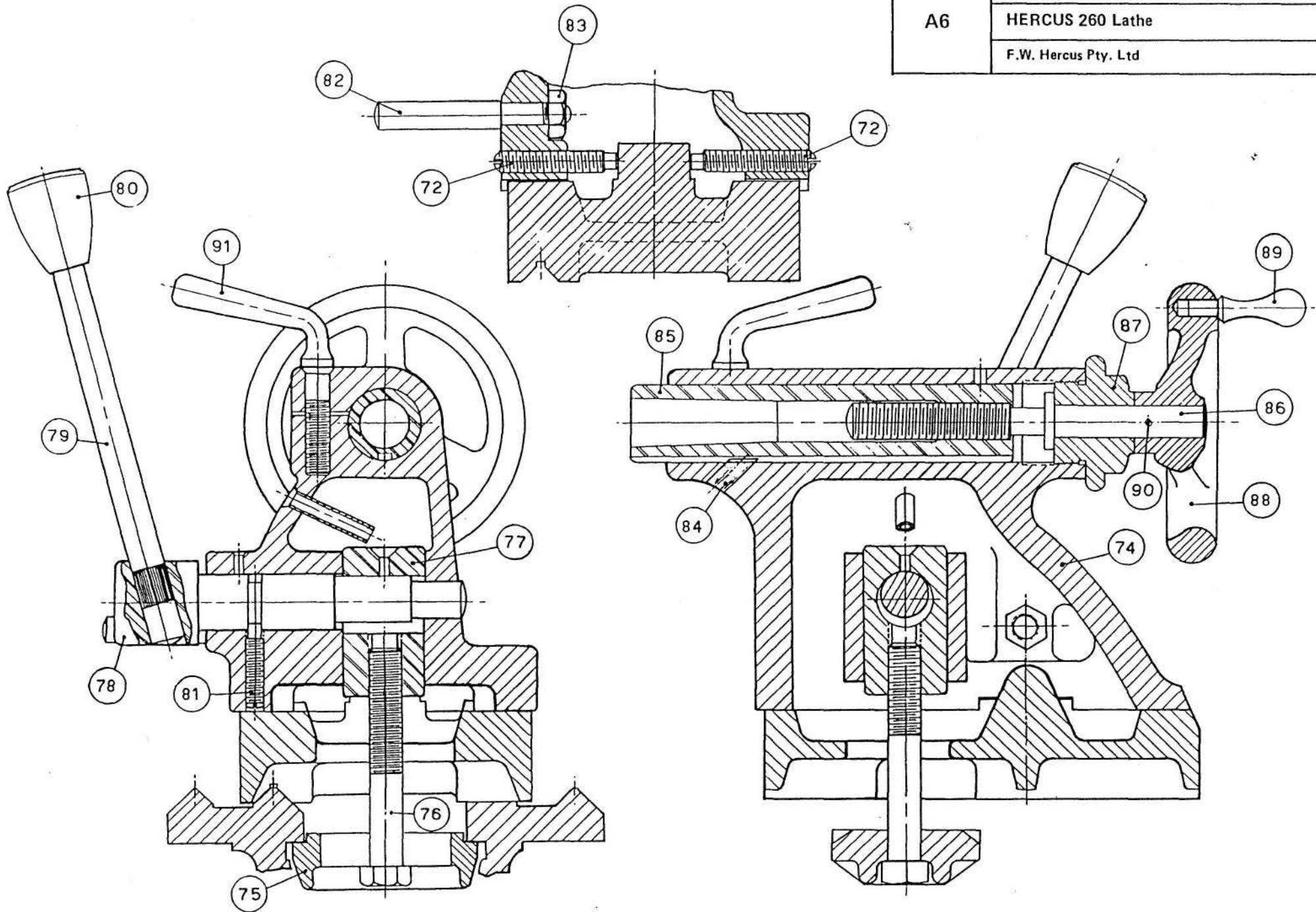

SINGLE TOOL POST:

A12	A. M. Apron Saddle and Compound Rest	April 1980
A18	HERCUS 260 Lathe	
A23	F.W. Hercus Pty. Ltd.	

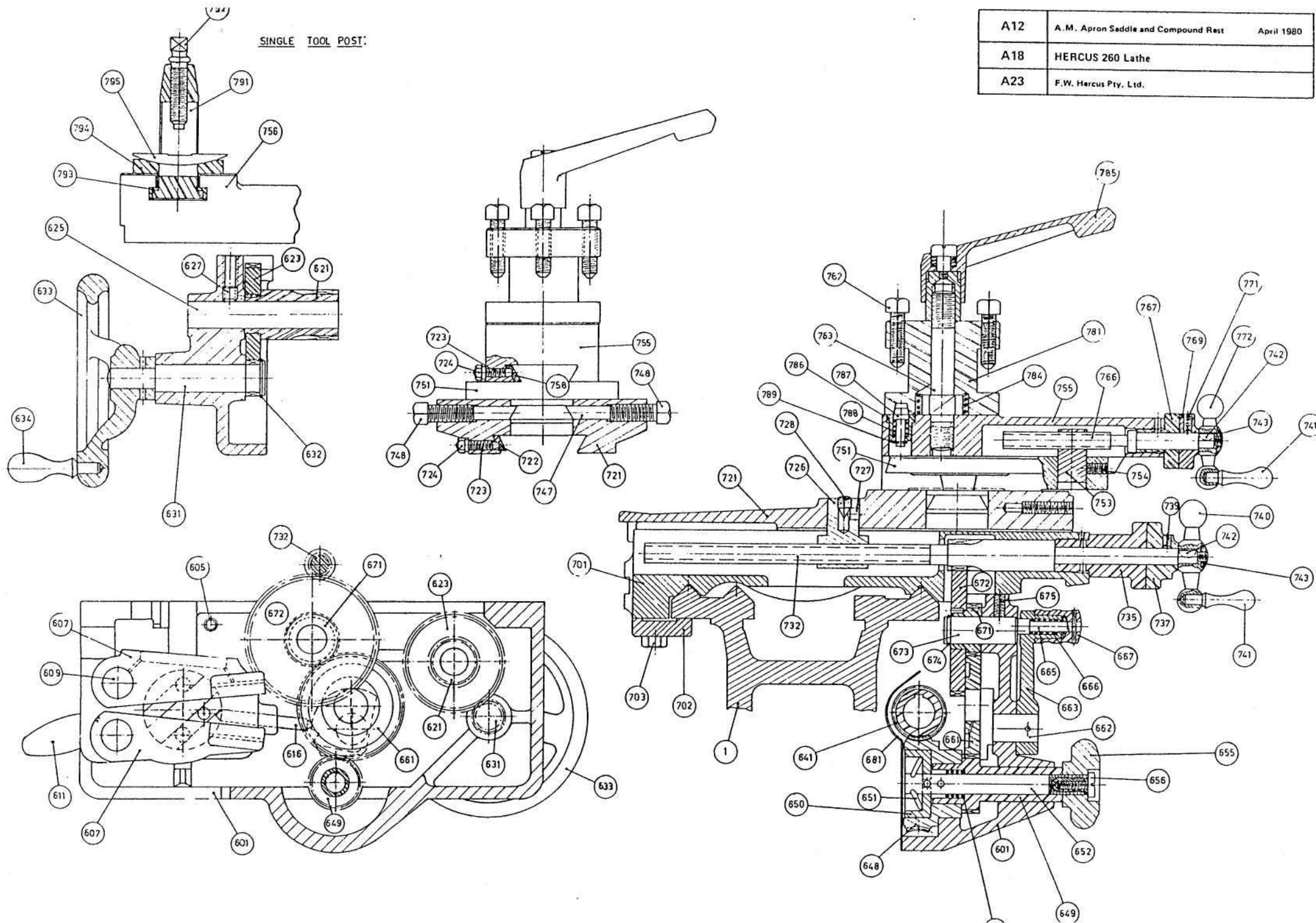

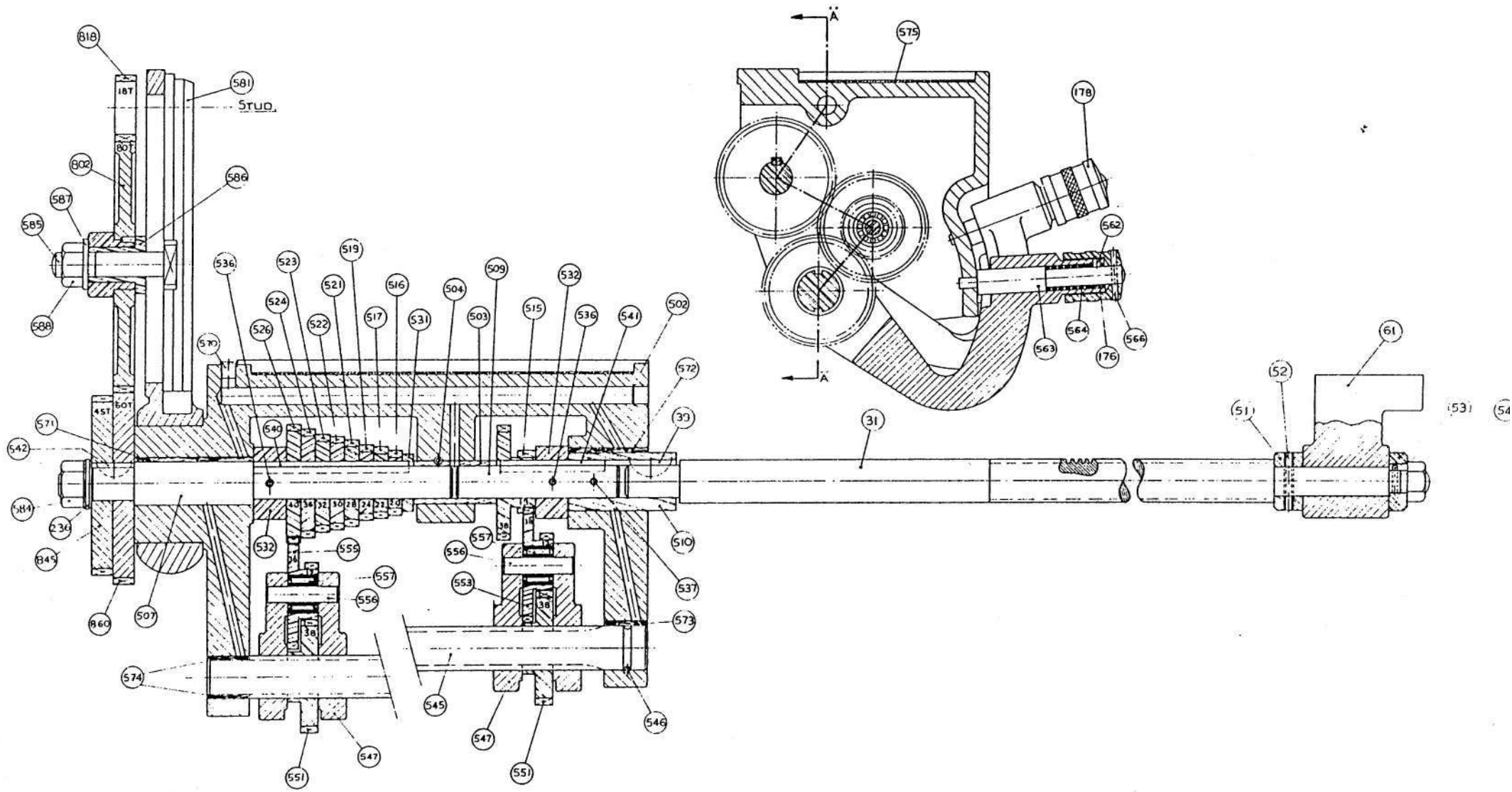

SECTION A A.

A9	A.M. Gearbox	April 1980
	Hercus 260 Lathe	
	F.W. Hercus Pty. Ltd.	

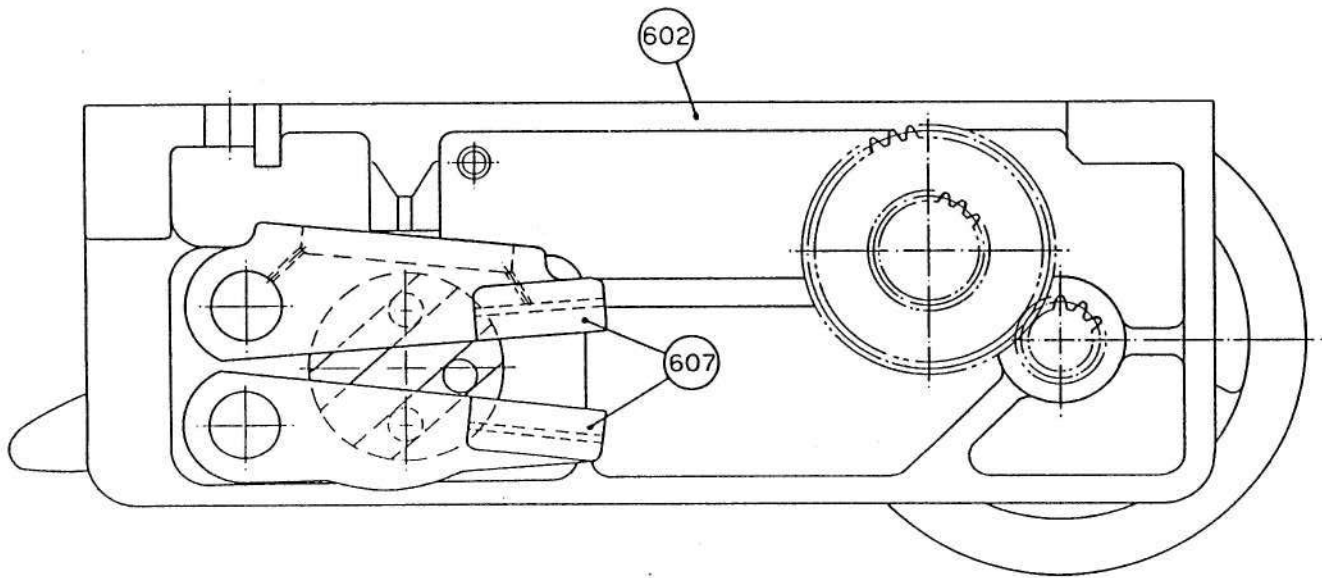
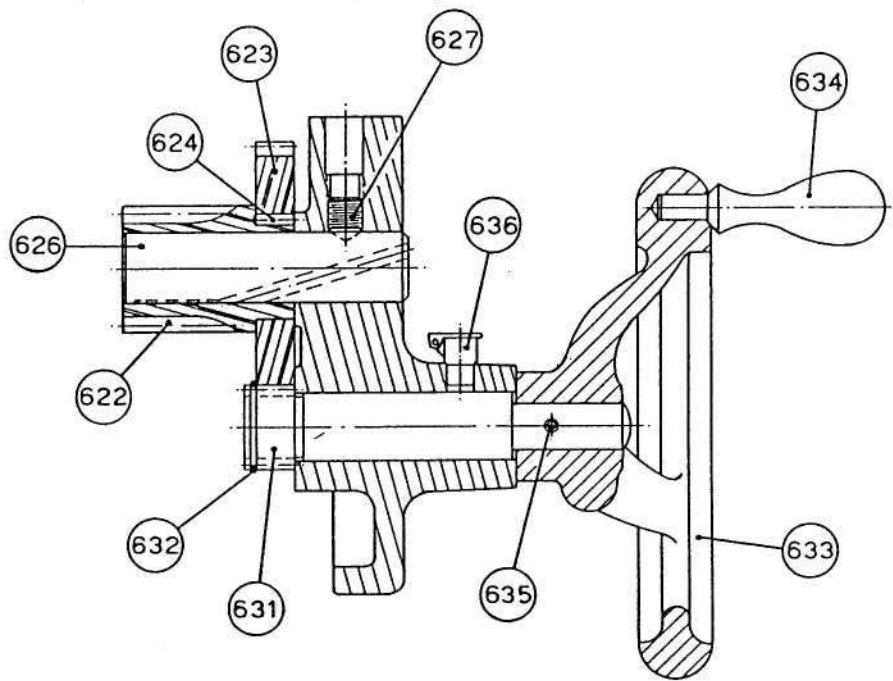
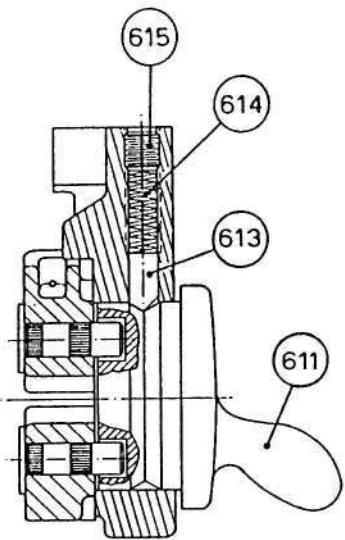
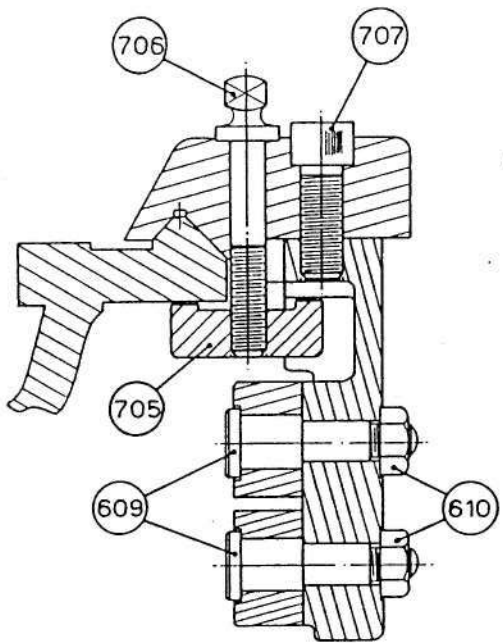

A14	Model CM Apron	April 1980
HERCUS 260 Lathe		
F.W. Hercus Pty. Ltd.		

A36	T. Drive Unit	April 1980
	HERCUS 260 Lathe	
	F.W. Mercus Pty. Ltd.	

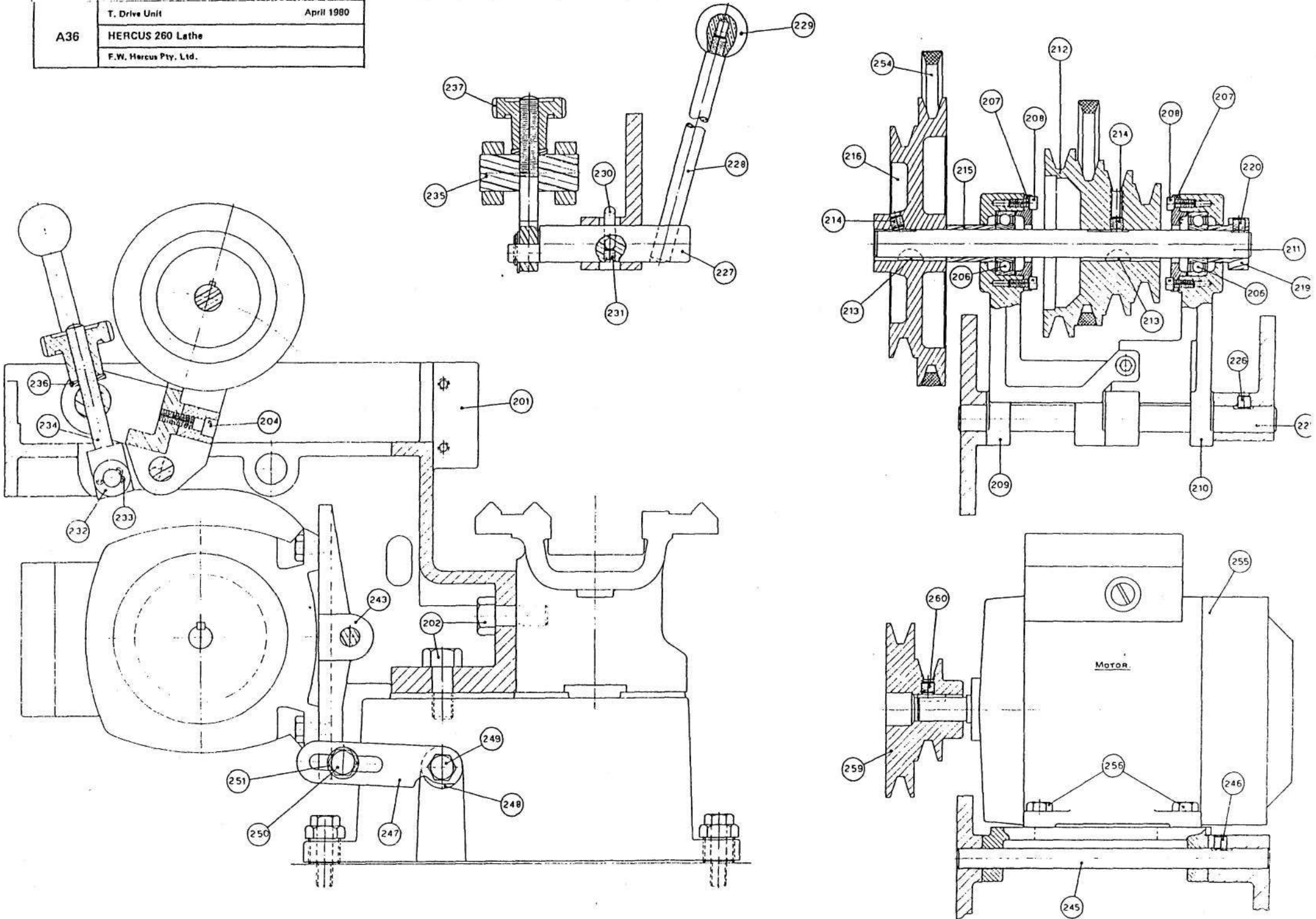

**APPENDIX "B"      Maintenance Tool Drawings**

M1                      Remove Spindle with Puller

M 2                      Replacing Spindle with Puller — Stage 1

M 3                      Replacing Spindle with Puller — Stage 2

M 4, M 5                Details of Spindle Puller

M 6                      Details of Special Spanners



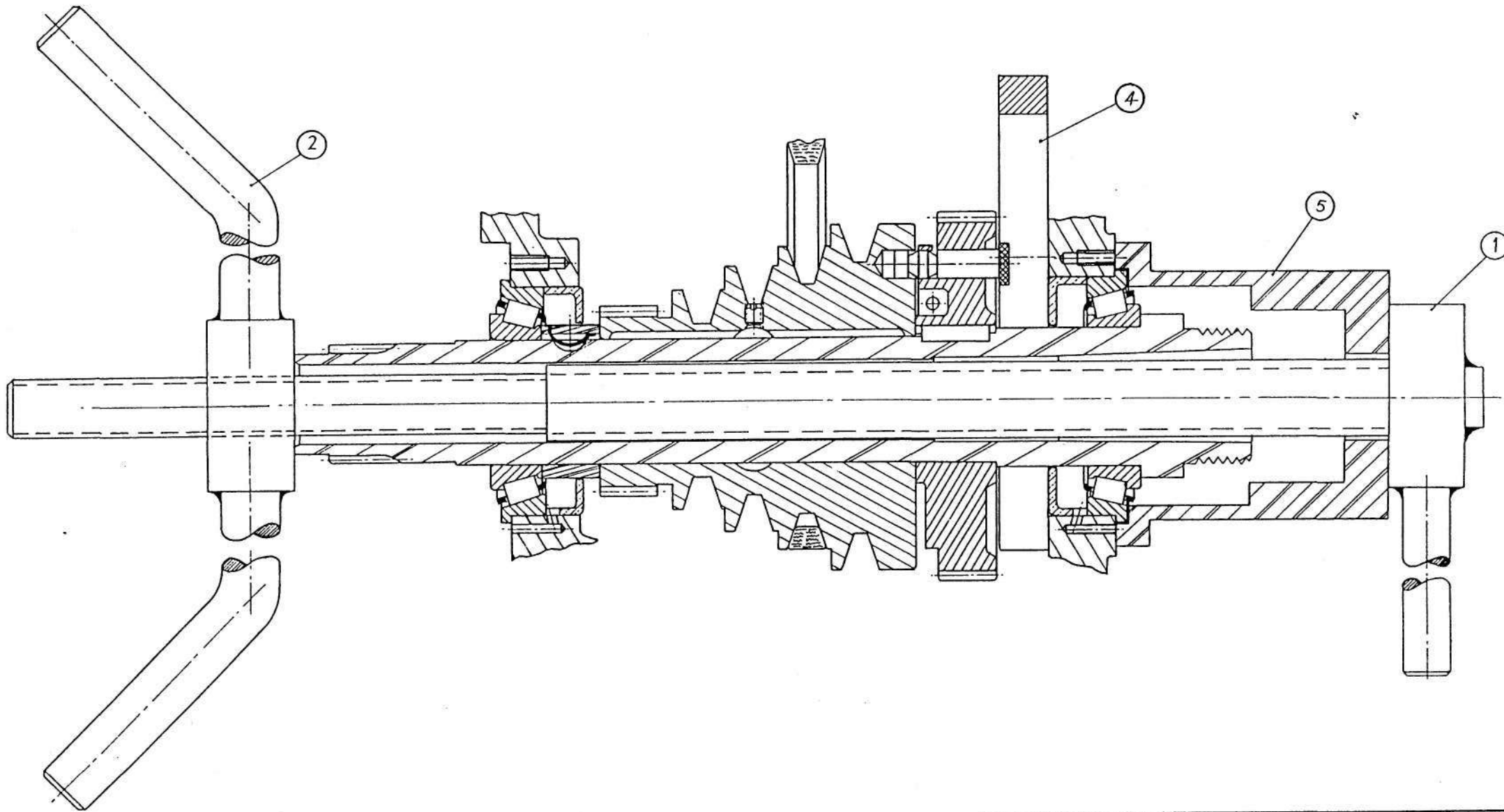

M1	Removing Spindle	April 1980
	HERCUS 260 Lathe	
	F.W. Hercus Pty. Ltd.	

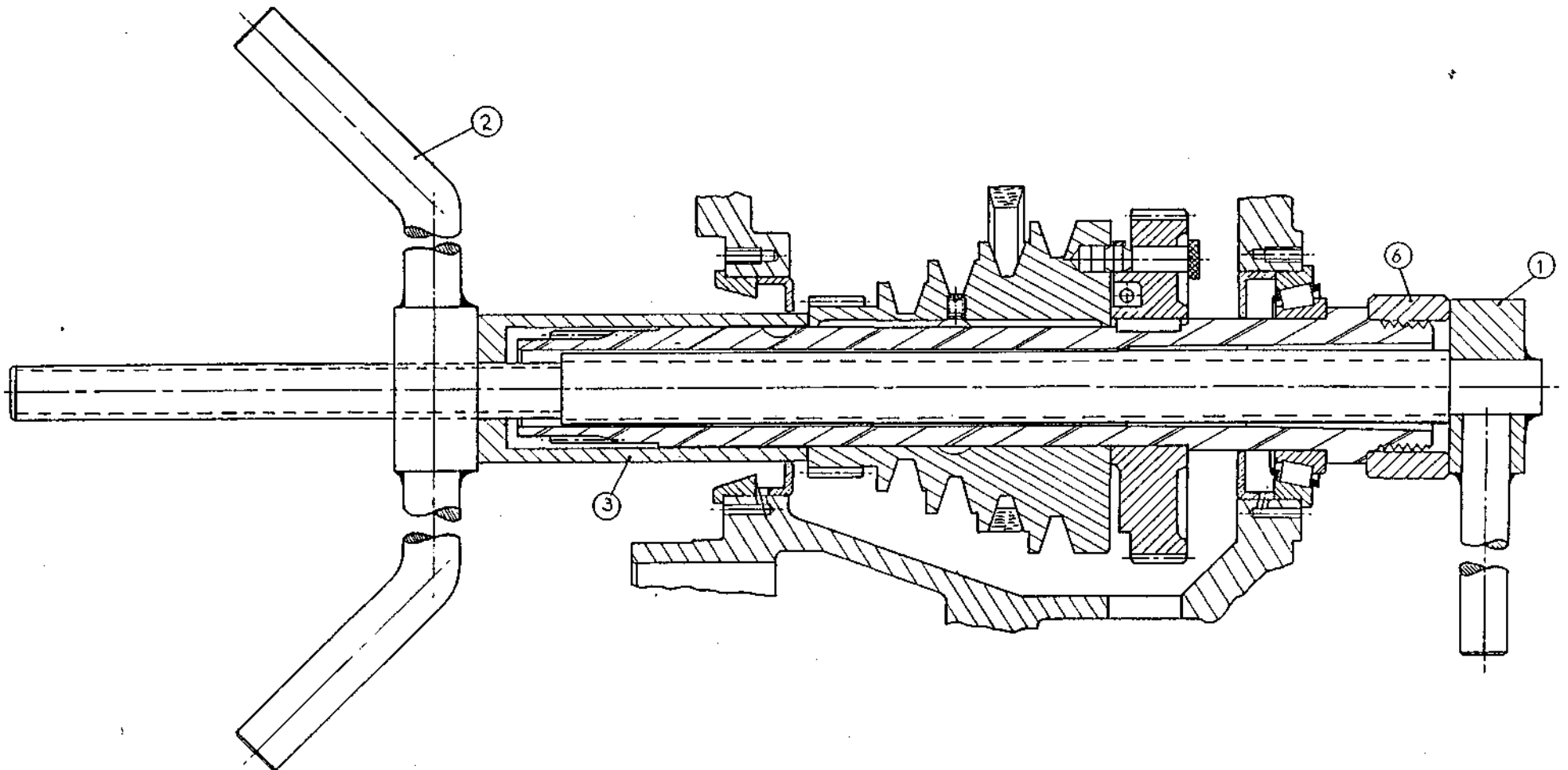

M2	Replacing Spindle	Stage 1	April 1980
	HERCUS 260 Lathe		
	F.W. Hercus Pty. Ltd.		

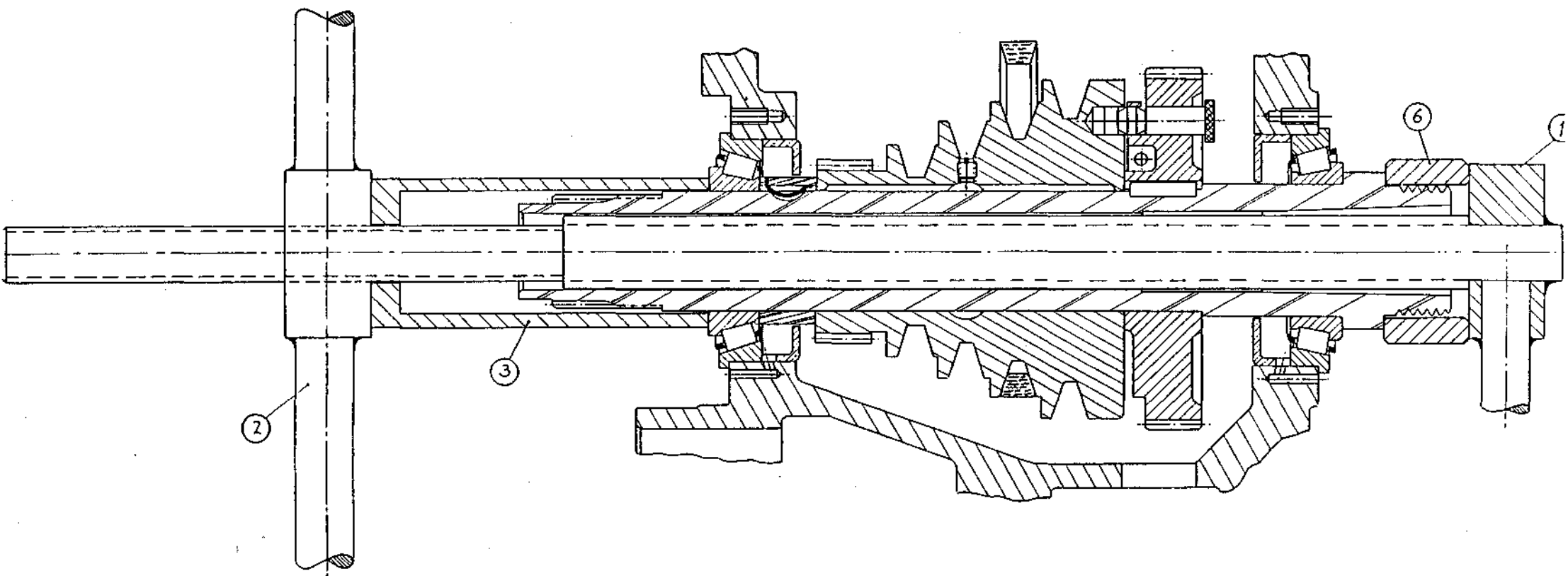

M3	Replacing Spindle	Stage 2	April 1980
	HERCUS 260 Lathe		

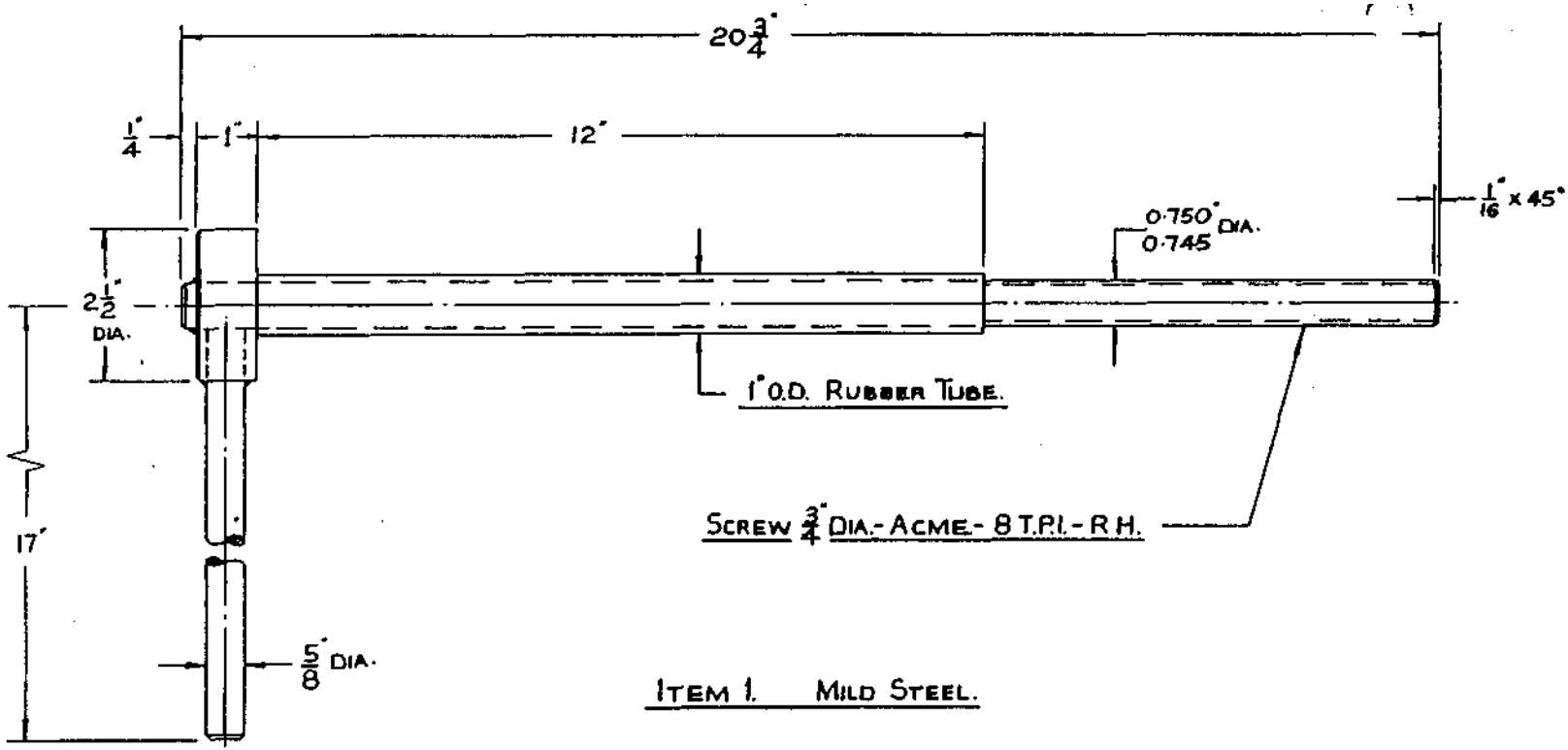

ITEM 1. MILD STEEL.

SCREW 3/4" DIA. - ACME - 8 T.P.I. - R.H.  
TO SUIT SCREW. (FREE FIT.)

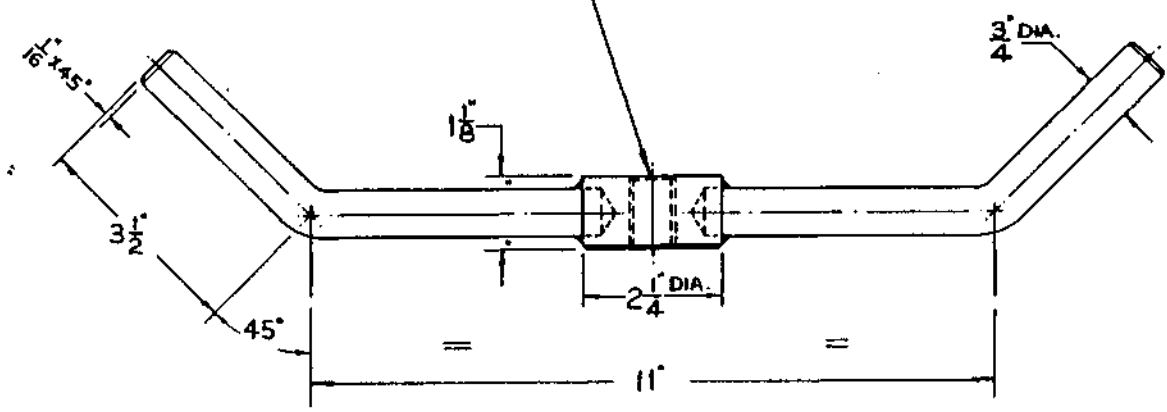

ITEM 2. MILD STEEL.

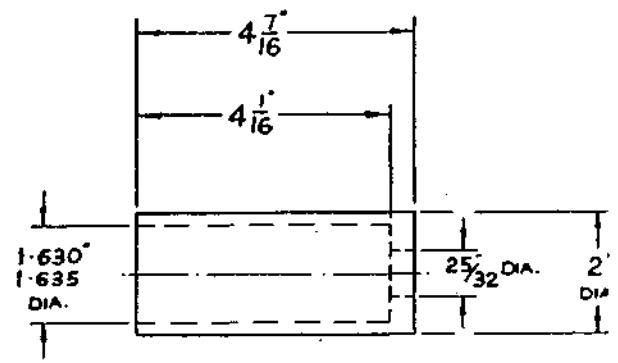

ITEM 3. MILD STEEL.

M4	SPINDLE PULLER.	APRIL 1980
	HERCUS 260 LATHE.	
	F.W.HERCUS PTY LTD.	THE BARTON, S.A.

MATERIAL - CUT  $\frac{5}{8}$ " SQUARE (OR 16MM) MILD STEEL X  $14\frac{1}{4}$ " LONG.

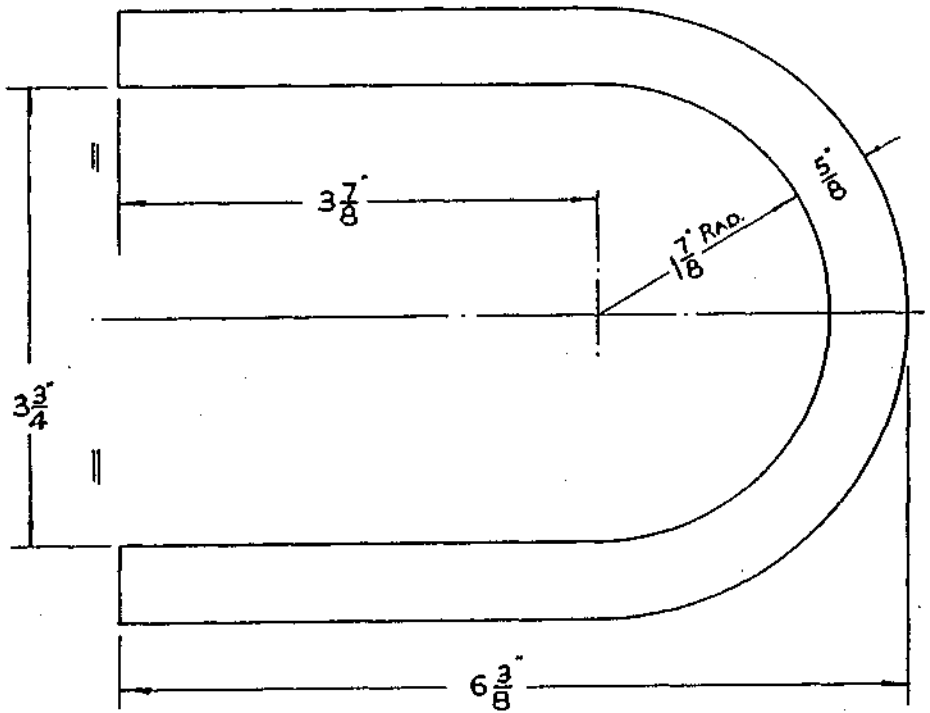

ITEM 4.

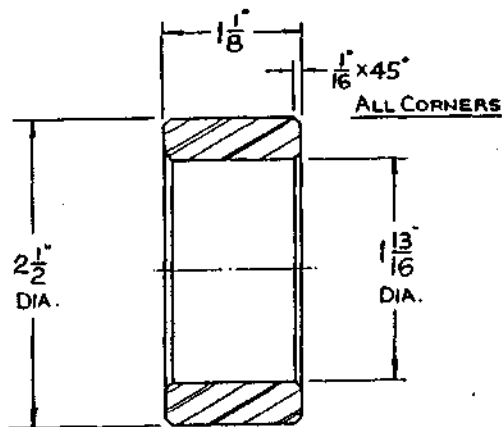

ITEM 6 MILD STEEL

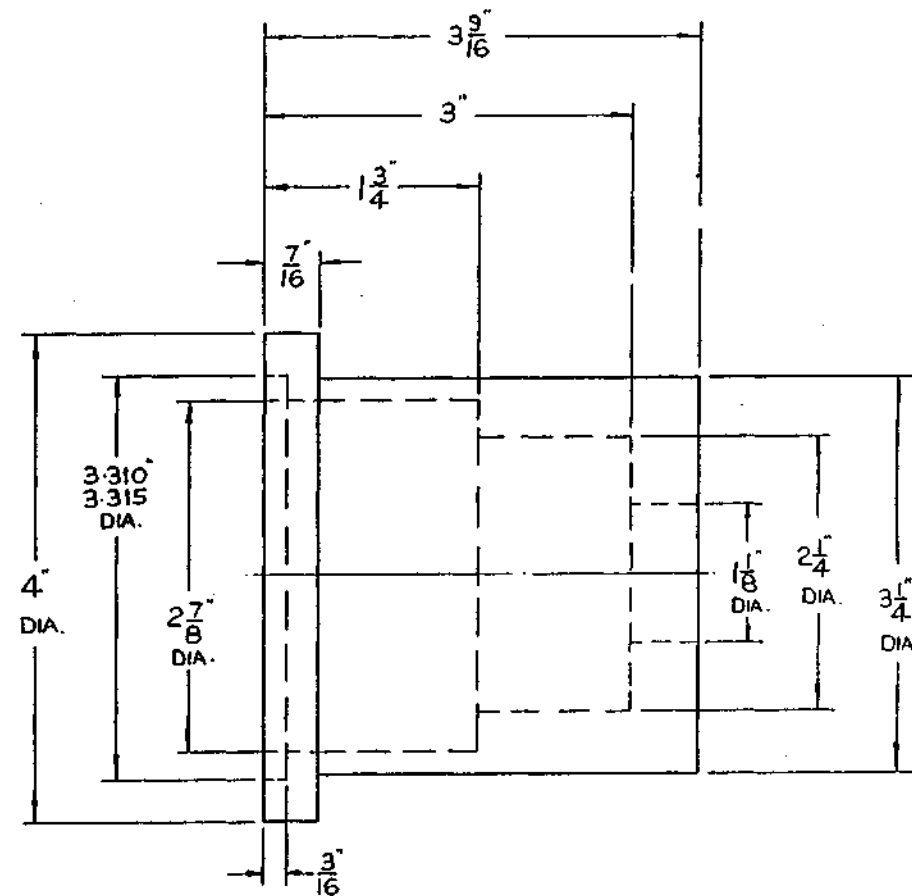
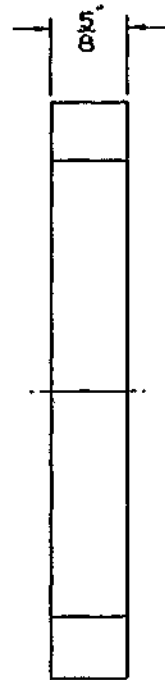

REMOVE SHARP EDGES.  
ITEM 5. - MILD STEEL.

M5	SPINDLE PULLER.	APRIL 1980
	HERCUS 260 LATHE.	
	F.W.HERCUS PTY. LTD.	THE BARTON SA.

B1- FUJI RCa470FG1 GREEN START PUSH BUTTON.  
 B2- FUJI RCa 470MR1 RED STOP PUSH BUTTON.  
 S1- SIEMENS 3TB42-12-0A CONTACTOR  
 REVERSING SWITCH-KRAUS & NAIMER-C18-A401  
 F1 & F2 - FEDERAL 20C 6.  
 MOTOR- 1 PHASE - 50Hz - 240 VOLTS  
 M1- MICRO-SWITCH-NORMALLY CLOSED- SAFETY SWITCH.  
 ISOLATING SWITCH - FEDERAL WR320.

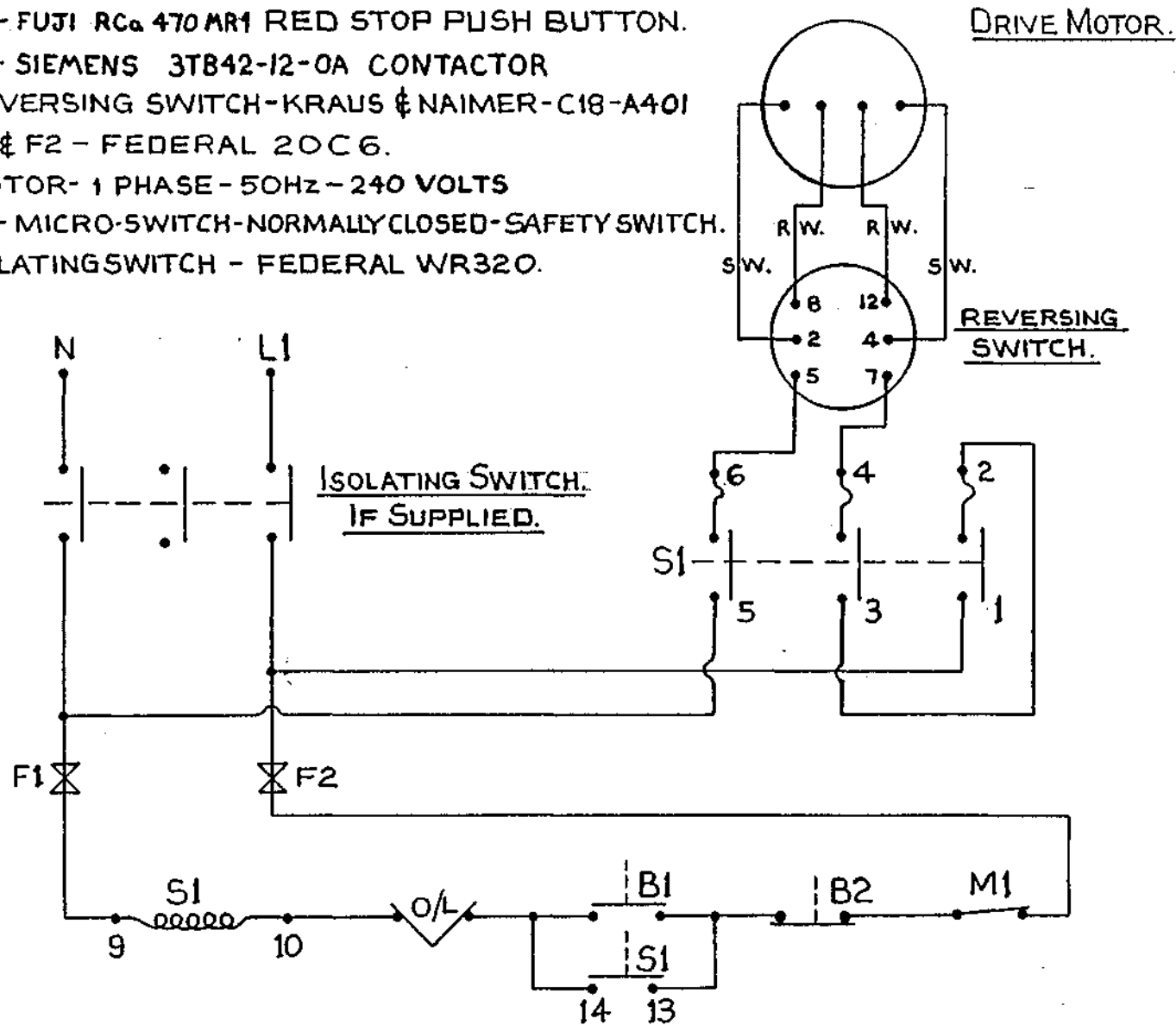

SINGLE PHASE STANDARD WIRING DIAGRAM.

HERCUS 260 LATHE.

28/9/77

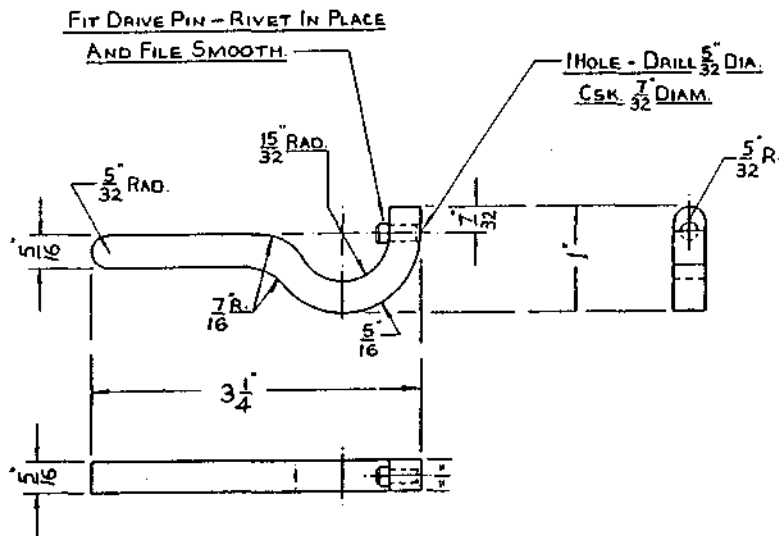

CASE HARDEN 0.005/0.010" DEEP AFTER FITTING DRIVE PIN.

CROSS SLIDE BUSHING SPANNER - MILD STEEL.

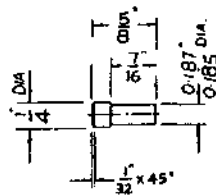

DRIVE PIN FOR TAKE UP NUT SPANNER - MILD STEEL.

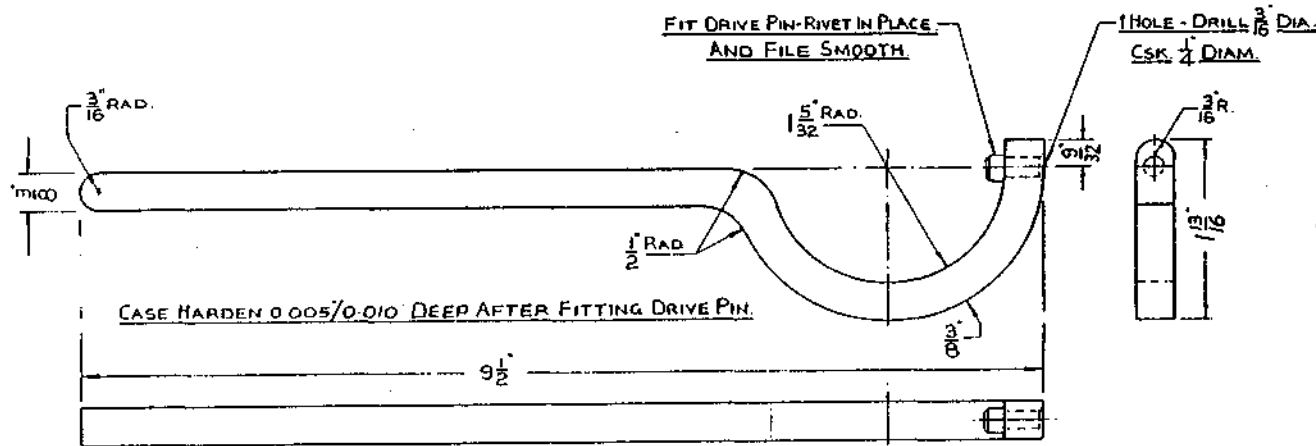

CASE HARDEN 0.005/0.010" DEEP AFTER FITTING DRIVE PIN.

SPINDOLE TAKE UP NUT SPANNER - MILD STEEL.

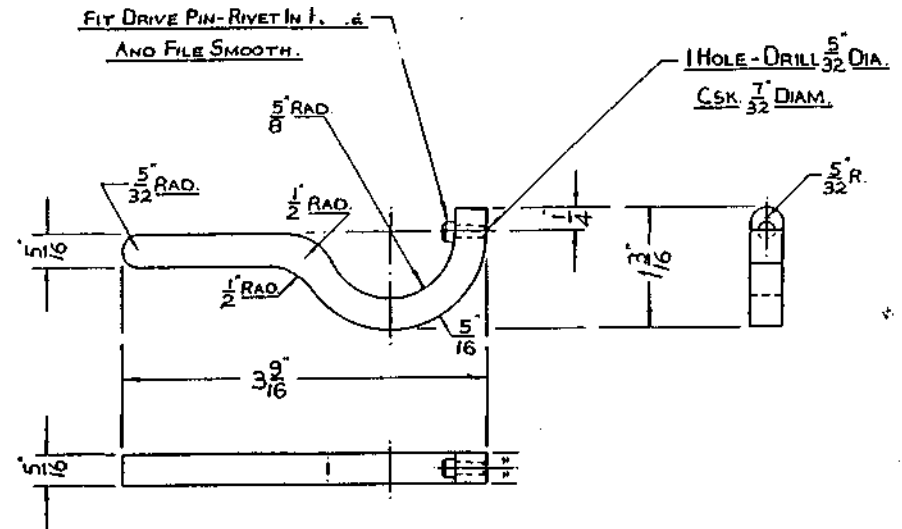

CASE HARDEN 0.005/0.010" DEEP AFTER FITTING DRIVE PIN.

TOP SLIDE BUSHING SPANNER - MILD STEEL.

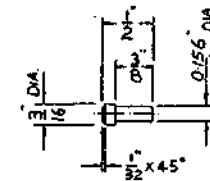

DRIVE PIN FOR BUSHING SPANNERS - MILD STEEL.

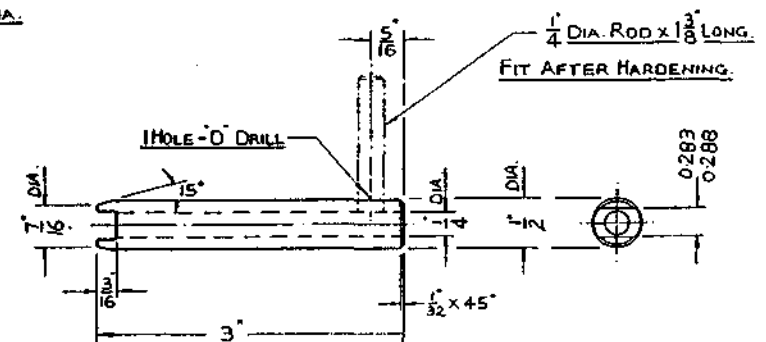

CASE HARDEN 0.005/0.010" DEEP.

GIB SCREW LOCKNUT SPANNER - MILD STEEL.

M6	Special Spanners
HERCULES 260 Lathe	
F.W. Hercules Pty. Ltd. Thebarton S.A.	
April 1980	

**APPENDIX "C"      List of other material on 260 Lathe**

- 1/ Text Book of Turning
- 2/ Spare Parts Book
- 3/ Wall Chart of Lathe
- 4/ Set of 12 Transparencies for Overhead Projector
- 5/ Video Programme on Basic Lathe Instruction
- 6/ Video Programme on Lathe Maintenance

For further details, contact your local HERCUS Distributor or —

**F.W. HERCUS**  
**12 CAMIRA STREET**  
**REGENCY PARK, S. AUST. 5010**  
**PH5346 5522    FAXS346 5811**